



FLOW TEMP. CONTROLLER [MASTER] (Cased)

PAC-IF051B-E

PAC-IF052B-E

FLOW TEMP. CONTROLLER [SLAVE] (Cased)

PAC-SIF051B-E

INSTALLATION MANUAL

FOR INSTALLER

For safe and correct use, read this manual thoroughly before installing the FTC4 unit.

OPERATION MANUAL

FOR USER

For safe and correct use, please read this operation manual thoroughly before operating the FTC4 unit.

English

Contents

1. Safety precautions.....	2	7. Main controller operation.....	32
2. Installing the FTC4 unit	3	8. Troubleshooting	51
3. System	5	9. Multiple outdoor units control	56
4. Electrical work	11	10. Supplementary information (Pump down).....	69
5. Dip switch setting	26	Local application factors	70
6. Before test run.....	31		

"FTC4 (Master)" is the abbreviation of "Flow Temperature Controller [Master]", which is described as "FTC4 (Master)" in this manual.

"FTC4 (Slave)" is the abbreviation of "Flow Temperature Controller [Slave]", which is described as "FTC4 (Slave)" in this manual.

In this manual, "FTC4" that is not followed by "(Master)" or "(Slave)" means "FTC4 (Master and Slave)".

Mitsubishi Electric is not responsible for the failure of locally supplied parts.

1. Safety precautions

FOR INSTALLER

- ▶ Before installing the FTC4 unit, make sure you read all the "Safety precautions".
- ▶ Please report to your supply authority or obtain their consent before connecting this equipment to the power supply system.

⚠ Warning:

Precautions that must be observed to prevent injuries or death.

⚠ Caution:

Precautions that must be observed to prevent damage to the unit.

After installation, perform the test run to ensure normal operation. Then explain to your customer the "Safety Precautions" *1, use, and maintenance of the unit based on the information in this manual. This manual must be given to the user. This manual must always be kept by the actual users.

*1 "Safety Precautions" for user is indicated on page 32.

⚠ : This indicates a part which must be grounded.

⚠ Warning:

Carefully read the labels attached to the unit.

⚠ Warning:

- The unit must not be installed by the user. Ask an installer or an authorized technician to install the unit. If the unit is installed improperly, electric shock, or fire may be caused.
- For installation work, follow the instructions in the Installation Manual and use tools and pipe components specifically made for use with refrigerant specified in the outdoor unit installation manual.
- The unit must be installed according to the instructions in order to minimize the risk of damage by earthquakes, typhoons, or strong winds. Improperly installed units may fall down and cause damage or injuries.
- The unit must be securely installed on a structure that can sustain its weight. If the unit is mounted on an unstable structure, it may fall down and cause damage or injuries.
- All electric work must be performed by a qualified technician according to local regulations and the instructions given in this manual. The unit must be powered by dedicated power lines and the correct voltage and circuit breakers must be used. Power lines with insufficient capacity or incorrect electrical work may result in electric shock or fire.

- Only the specified cables can be used for wiring. Connections must be made securely without tension on the terminals. If cables are connected or installed improperly, it may result in overheating or fire.
- Terminal block cover panel of the unit must be firmly fixed. If the cover panel is mounted improperly, dust and moisture may enter the unit, and it may cause electric shock or fire.
- Make sure to use accessories authorized by Mitsubishi Electric and ask an installer or an authorized technician to install them. If accessories are improperly installed, it may cause electric shock, or fire.
- Do not remodel the unit. Consult an installer for repairs. If alterations or repairs are not performed correctly, it may cause electric shock or fire.
- The user should never attempt to repair the unit or transfer it to another location. If the unit is installed improperly, it may cause electric shock or fire. If the FTC4 unit needs to be repaired or moved, ask an installer or an authorized technician.
- During installing a heat pump system, keep water from splashing on the FTC4 unit.
- When installing sensors and parts, do not expose the terminals.

1.1 Before installation (Environment)

⚠ Caution:

- Do not install the FTC4 unit in outdoor location as it is designed for indoor installation only. Otherwise electric shock or breakdown may be caused by water, wind or dust.
- Do not use the unit in an unusual environment. If the FTC4 unit is installed or exposed to steam, volatile oil (including machine oil), or sulfuric gas, or exposed to briny air, the internal parts can be damaged.
- Do not install the unit where combustible gases may leak, be produced, flow, or accumulate. If combustible gas accumulates around the unit, it may cause fire or explosion.

- When installing the unit in a hospital or in a building where communications equipment are installed, you may need to take measures to prevent noise and electronic interference. Inverters, home appliances, high-frequency medical equipment, and radio communications equipment can cause the FTC4 unit to malfunction or to breakdown. At the same time, the noise and electric interference from the FTC4 unit may disturb the proper operation of nearby medical equipment, and communications equipment.

1.2 Before installation or relocation

⚠ Caution:

- Be very careful when moving the units. Do not hold the packaging bands. Wear protective gloves to unpack and to move the units, in order to avoid injury to your hands.

- Be sure to safely dispose of the packaging materials. Packaging materials, such as nails and other metal or wooden parts may cause injuries.
- Do not wash the FTC4 unit. You may receive an electric shock.

1.3 Before electric work

⚠ Caution:

- Be sure to install a circuit breaker. If it is not installed, there may be a risk to get an electric shock.
- For the power lines, use standard cables of sufficient capacity. Otherwise, it may cause a short circuit, overheating, or fire.
- When installing the power lines, do not apply tension to the cables. The cables may be cut or overheated resulting in a fire.

- Make sure to ground the unit. Do not connect the ground wire to gas or water pipes, lightning rods, or telephone grounding lines. If the unit is not properly grounded, there may be a risk to get an electric shock.
- Make sure to use circuit breakers (ground fault interrupter, isolating switch (+B fuse), and molded case circuit breaker) with the specified capacity. If the circuit breaker capacity is larger than the specified capacity, breakdown or fire may result.

1. Safety precautions

1.4 Before starting the test run

⚠ Caution:

- Turn on the main power switch of the outdoor unit more than 12 hours before starting operation. Starting operation immediately after turning on the power switch can severely damage the internal parts. Keep the main power switch turned on during the operation period.
- In heating mode, to avoid the heat emitters being damaged by excessively hot water, set the target flow temperature to a minimum of 2°C below the maximum allowable temperature of all the heat emitters. For Zone2, set the target flow temperature to a minimum of 5°C below the maximum allowable flow temperature of all the heat emitters in Zone2 circuit.
- Before starting operation, check that all protective parts are correctly installed. Make sure not to get injured by touching high voltage parts.
- Do not touch any switch with wet hands. There may be a risk to get an electric shock.
- After stopping operation, make sure to wait at least 5 minutes before turning off the main power. Otherwise, it may cause breakdown.

1.5 Electric booster and immersion heaters

⚠ Warning:

- FTC4 has signal outputs for heaters however it can not isolate power to them in the event of overheating. All electrical heaters used on the water circuit must have
 - a) A thermostat to prevent overheating.
 - b) A non-self resetting thermal mechanism to prevent overheating.

Abbreviations and glossary

Abbreviations/Word	Description
Ambient temperature	The outdoor temperature
Freeze stat. function	Heating to prevent water pipes freezing
ASHP/HP	Air source heat pump
COP	Coefficient of performance the efficiency of the heat pump
Cylinder unit	Indoor unvented DHW tank and component plumbing parts
Hydrobox	Indoor unit housing the component plumbing parts (NO DHW tank)
DeltaT	Difference in temperature between two system locations.
DHW mode	Domestic hot water heating mode for showers, sinks, etc
Flow rate	Speed at which water circulates around the primary circuit
Flow temperature	Temperature at which water is delivered to the primary circuit
FTC4 (Master)	Flow temperature controller, the circuit board in charge of controlling the system, master board for multiple outdoor units control
FTC4 (Slave)	Slave board for multiple outdoor units control
Compensation curve mode	Space heating incorporating outdoor temperature compensation
Heating mode	Space heating through radiators or UFH
Cooling mode	Space cooling through radiators or UFC
Legionella	Bacteria potentially found in plumbing, showers and water tanks that may cause Legionnaires disease
LP mode	Legionella prevention mode – a function on systems with tanks to prevent the growth of legionella bacterium
Packaged model	Plate heat exchanger in the outdoor heat pump unit
Refrigerant	A compound used within the heat cycle that goes through a phase change from gas to liquid
Split model	Plate heat exchanger in the indoor unit
TRV	Thermostatic radiator valve – a valve on the entrance or exit of the radiator panel controlling the heat output
UFH	Under floor heating – a system of water carrying pipes under the floor, that warms the floor surface
UFC	Under floor cooling – a system of water carrying pipes under the floor, that cools the floor surface

2. Installing the FTC4 unit

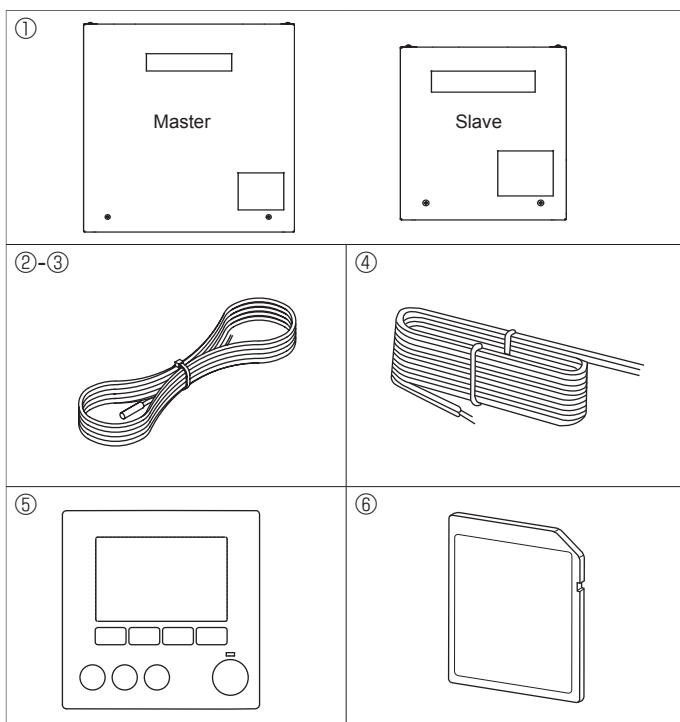

<Fig. 2.1.1>

2.1. Check the parts (Fig. 2.1.1)

The FTC4 unit should be supplied with the following parts.

	Part name	Wiring diagram symbol	Q'ty
①	FTC4 (master) unit: PAC-IF051/052B-E FTC4 (slave) unit: PAC-SIF051B-E		1
②	Liquid refrigerant temp. thermistor (Lead wire: 5m/Red, Connector: 3p/Yellow)	TH2	1 *1
③	Flow water temp. and Return water temp. thermistor (Lead wire: 5m/Gray(Flow water temp.), 5m/Black(Return water temp.), Connector: 4p/Red)	THW1/2	1
④	Main controller cable (10 m)		1
⑤	Main controller		1 *2
⑥	SD memory card		1

*1 Not included with PAC-IF052B-E.

*2 Not included with PAC-SIF051B-E.

2. Installing the FTC4 unit

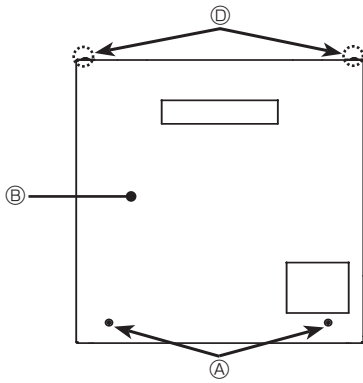

<Fig. 2.3.1>

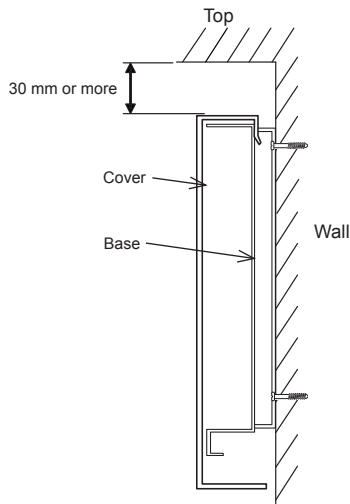

<Fig. 2.3.2>
Service space

2.2. Choosing the FTC4 unit installation location

- Do not install the FTC4 units outdoors as it is designed for indoor installation only. (The FTC4 circuit board and casing are not waterproof.)
- Avoid locations where the unit is exposed to direct sunlight or other sources of heat.
- Select a location where easy wiring access to the power source is available.
- Avoid locations where combustible gases may leak, be produced, flow, or accumulate.
- Select a level location that can bear the weight and vibration of the unit.
- Avoid locations where the unit is exposed to oil, steam, or sulfuric gas.
- Do not install in location that is hot or humid for long periods of time.

2.3. Installing the FTC4 unit (Fig. 2.3.1, 2.3.2, 2.3.3, 2.3.4)

1. Remove 2 screws (A Screw) from FTC4 unit and remove the cover. (See Fig. 2.3.4)
2. Install the 4 screws (locally supplied) in the 4 holes (C Hole).
* To prevent the unit from falling off the wall, select the appropriate screws (locally supplied) and secure the base horizontally to the appropriate wall location. (See Fig. 2.3.2)

- (A) Screw (B) Cover
(C) Hole for installation (D) Screw

Note: Do not remove the screws (D) as the screws are the component parts of the cover and are not used for the installation of cover.

Weight	*** kg + ACCESSORIES *** kg
Allowable ambient temperature	0 to 35°C
Allowable ambient humidity	80% RH or less

Optional extras

- Wireless Remote Controller PAR-WT50R-E
- Wireless Receiver PAR-WR51R-E
- Remote sensor PAC-SE41TS-E

<FTC4 (Master) unit>

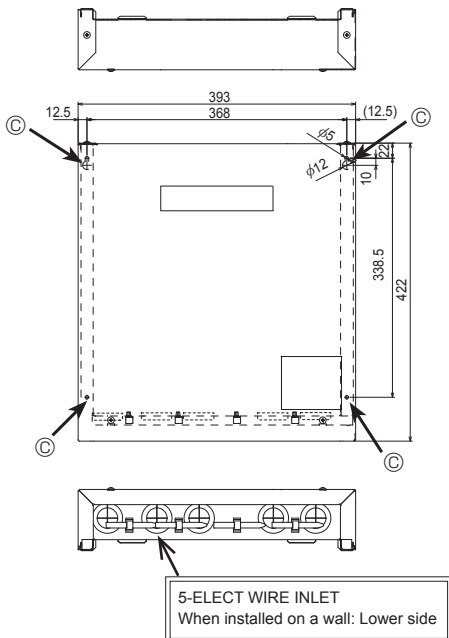

<FTC4 (Slave) unit>

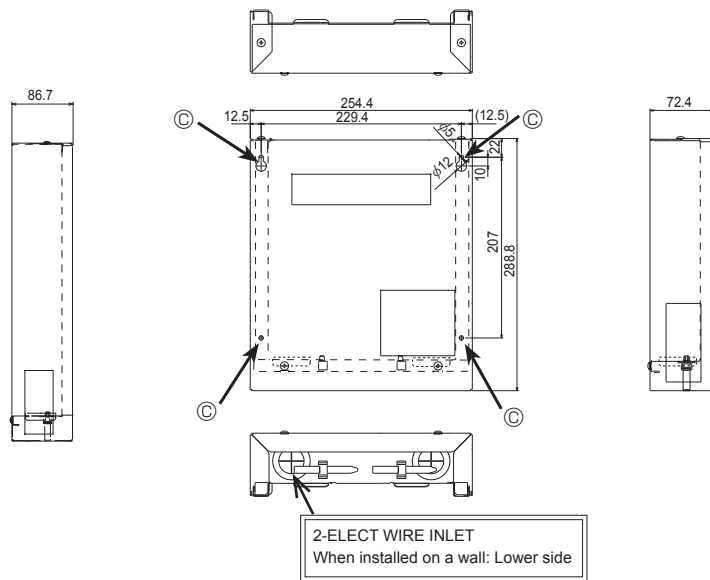

<Fig. 2.3.3>

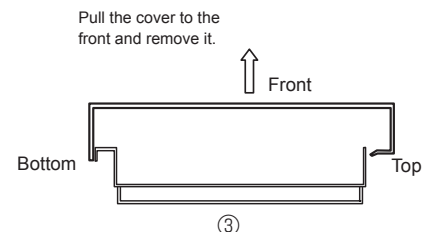
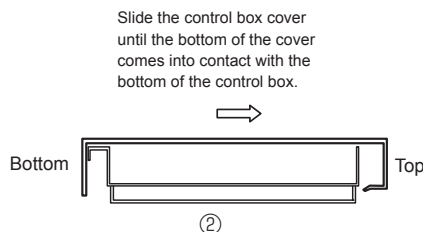
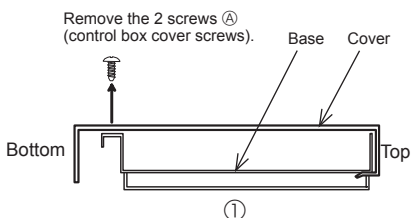

<Fig. 2.3.4>

3. System

The FTC4 (Master) is designed for use with a number of heat pump systems. Please refer to the following table to find the relevant installation information for your system. For multiple outdoor units control with FTC4 (Slave), see section 9.

3.1 First step (Electrical work)

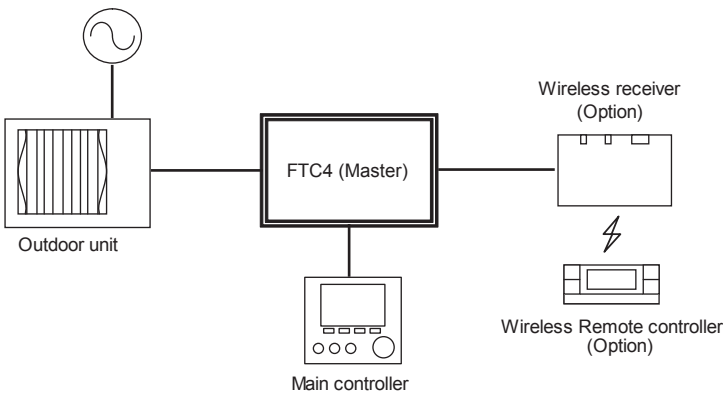
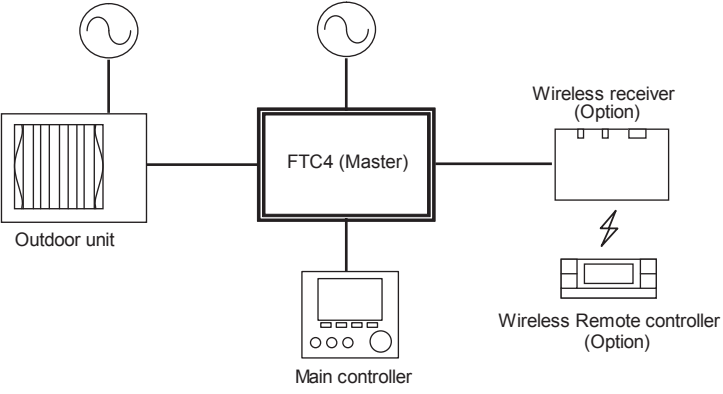
Power supplies	System diagram	Reference section
FTC4 (Master) powered via outdoor unit		4.1 4.2
FTC4 (Master) powered by independent source		4.1 4.2

3.2 Second step (Outdoor unit type)

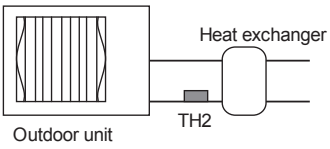
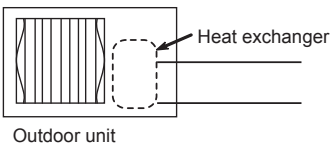
Outdoor unit type	System diagram	Thermistor	Reference section
Split		TH2: Liquid refrigerant temp.	4.4 5.2
Packaged		—	4.4 5.2

* PAC-IF052B-E is not available for Split-type system.

3. System

3.3 Third step (Functions setting)

DHW tank	Immersion heater	Booster heater	BH function	System diagram	Thermistor	Reference section	Remarks
Present	Absent	Present	For heating and DHW		THW1: Flow water temp. THW2: Return water temp. THW5: Tank water temp.	4.4 4.5 5.3	
Present	Present	Present	For heating and DHW		THW1: Flow water temp. THW2: Return water temp. THW5: Tank water temp.	4.4 4.5 5.3	
Present	Absent	Present	For heating only		THW1: Flow water temp. THW2: Return water temp. THW5: Tank water temp.	4.4 4.5 5.3	1. 'Legionella Prevention Mode' cannot be selected in this system.
Present	Absent	Absent	—		THW1: Flow water temp. THW2: Return water temp. THW5: Tank water temp.	4.4 4.5 5.3	1. 'Legionella Prevention Mode' cannot be selected in this system. 2. Please make sure water circuit not to get frozen during defrost.
Present	Present	Present	For heating only		THW1: Flow water temp. THW2: Return water temp. THW5: Tank water temp.	4.4 4.5 5.3	
Present	Present	Absent	—		THW1: Flow water temp. THW2: Return water temp. THW5: Tank water temp.	4.4 4.5 5.3	
Absent	Absent	Present	—		THW1: Flow water temp. THW2: Return water temp.	4.4 4.5 5.3	
Absent	Absent	Absent	—		THW1: Flow water temp. THW2: Return water temp.	4.4 4.5 5.3	1. Please make sure water circuit not to get frozen during defrost.

* The use of two 2-way valves can perform same function as a 3-way valve.

3. System

3.4 Fourth step (Functions setting)

* Make sure to check the followings for your safety when designing a system. These are the minimum requirement for the safe use of FTC4 unit.

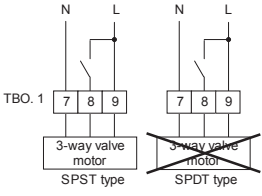
Parts name	Requirement																																																							
Flow switch	It is required to protect system from the effects of insufficient flow.																																																							
Strainer /Magnetic filter (water circuit)	Provide it as required to protect parts from damages caused by iron particles/water/contamination (e.g. the position before pump and return part from emitters).																																																							
Pressure relief valve (Primary circuit side) (Sanitary water side)	It is required to protect system from reaching high pressure. Select the operating pressure depending on water pressure in the circuit in normal use. ※ Follow the national regulations.																																																							
3-way valve	<p>Current: 0.1A Max (If over 0.1A you must use a relay) Power supply: 230V AC Connect earth cable, if there is one. Type: SPST ※ SPDT type can NOT be used.</p> 																																																							
2-way valve	<p>Current: 0.1A Max (If over 0.1A you must use a relay) Power supply: 230V AC Connect earth cable, if there is one. Type: Normally closed Select the 2-way valve that slowly opens and shuts off to prevent water hammer. A by-pass valve or circuit should be installed between pump and 2-way valve for safety (to release pressure when the both 2-way valves are closed). Select a 2-way valve equipped with manual override, which is necessary for topping up or draining of water.</p>																																																							
Water circulation pump	<p>Current: 1.0A Max, Power supply: 230V AC When connecting a pump with an electric current of $\geq 1A$ or multiple pumps, please note the following.</p> <ol style="list-style-type: none"> Use (a) relay(s). When power is supplied from outdoor unit, TOTAL current (including the other parts) requirement MUST be $\leq 3A$ (otherwise, the fuse on the outdoor unit PCB will blow.) When independent power supplies (i.e. from the FTC4 unit itself) , total current for the pump(s) is $\leq 3A$. (otherwise, the fuse on the FTC4 PCB will blow.) <p>Connect earth cable, if there is one. Adjust the pump speed setting so that the flow rate in the primary circuit is appropriate for the outdoor unit installed see the table and figures below.</p> <table border="1" data-bbox="319 1160 922 1848"> <thead> <tr> <th colspan="2">Outdoor heat pump unit</th> <th>Water flow rate range [L/min]</th> </tr> </thead> <tbody> <tr> <td rowspan="4">Packaged</td> <td>PUHZ-W50</td> <td>6.5 - 14.3</td> </tr> <tr> <td>PUHZ-W85</td> <td>10.0 - 25.8</td> </tr> <tr> <td>PUHZ-HW112</td> <td>14.4 - 32.1</td> </tr> <tr> <td>PUHZ-HW140</td> <td>17.9 - 40.1</td> </tr> <tr> <td rowspan="20">Split</td> <td>PUHZ-RP35</td> <td>5.0 - 11.8</td> </tr> <tr> <td>PUHZ-RP50</td> <td>7.0 - 17.2</td> </tr> <tr> <td>PUHZ-RP60</td> <td>8.6 - 20.1</td> </tr> <tr> <td>PUHZ-(H)RP71</td> <td>10.2 - 22.9</td> </tr> <tr> <td>PUHZ-(H)RP100</td> <td>14.4 - 32.1</td> </tr> <tr> <td>PUHZ-(H)RP125</td> <td>17.9 - 40.1</td> </tr> <tr> <td>PUHZ-RP140</td> <td>20.1 - 45.9</td> </tr> <tr> <td>PUHZ-RP200</td> <td>27.3 - 64.2</td> </tr> <tr> <td>PUHZ-HRP200</td> <td>28.7 - 68.9</td> </tr> <tr> <td>PUHZ-RP250</td> <td>32.1 - 80.3</td> </tr> <tr> <td>PUHZ-SW40</td> <td>5.0 - 11.8</td> </tr> <tr> <td>PUHZ-SW50</td> <td>7.0 - 17.2</td> </tr> <tr> <td>PUHZ-SW75</td> <td>10.2 - 22.9</td> </tr> <tr> <td>PUHZ-SW100</td> <td>14.4 - 32.1</td> </tr> <tr> <td>PUHZ-SW120</td> <td>20.1 - 45.9</td> </tr> <tr> <td>PUHZ-SW175</td> <td>27.3 - 64.2</td> </tr> <tr> <td>PUHZ-SW190</td> <td>32.1 - 80.3</td> </tr> <tr> <td>PUHZ-SHW80</td> <td>10.2 - 22.9</td> </tr> <tr> <td>PUHZ-SHW112</td> <td>14.4 - 32.1</td> </tr> <tr> <td>PUHZ-SHW140</td> <td>17.9 - 40.1</td> </tr> <tr> <td>PUHZ-SHW230</td> <td>28.7 - 68.9</td> </tr> </tbody> </table> <p>* The water velocity in pipes should be kept within certain limits of material to avoid erosion corrosion and excessive noise generation. (e.g. Copper pipe: 1.5m/s)</p>	Outdoor heat pump unit		Water flow rate range [L/min]	Packaged	PUHZ-W50	6.5 - 14.3	PUHZ-W85	10.0 - 25.8	PUHZ-HW112	14.4 - 32.1	PUHZ-HW140	17.9 - 40.1	Split	PUHZ-RP35	5.0 - 11.8	PUHZ-RP50	7.0 - 17.2	PUHZ-RP60	8.6 - 20.1	PUHZ-(H)RP71	10.2 - 22.9	PUHZ-(H)RP100	14.4 - 32.1	PUHZ-(H)RP125	17.9 - 40.1	PUHZ-RP140	20.1 - 45.9	PUHZ-RP200	27.3 - 64.2	PUHZ-HRP200	28.7 - 68.9	PUHZ-RP250	32.1 - 80.3	PUHZ-SW40	5.0 - 11.8	PUHZ-SW50	7.0 - 17.2	PUHZ-SW75	10.2 - 22.9	PUHZ-SW100	14.4 - 32.1	PUHZ-SW120	20.1 - 45.9	PUHZ-SW175	27.3 - 64.2	PUHZ-SW190	32.1 - 80.3	PUHZ-SHW80	10.2 - 22.9	PUHZ-SHW112	14.4 - 32.1	PUHZ-SHW140	17.9 - 40.1	PUHZ-SHW230	28.7 - 68.9
Outdoor heat pump unit		Water flow rate range [L/min]																																																						
Packaged	PUHZ-W50	6.5 - 14.3																																																						
	PUHZ-W85	10.0 - 25.8																																																						
	PUHZ-HW112	14.4 - 32.1																																																						
	PUHZ-HW140	17.9 - 40.1																																																						
Split	PUHZ-RP35	5.0 - 11.8																																																						
	PUHZ-RP50	7.0 - 17.2																																																						
	PUHZ-RP60	8.6 - 20.1																																																						
	PUHZ-(H)RP71	10.2 - 22.9																																																						
	PUHZ-(H)RP100	14.4 - 32.1																																																						
	PUHZ-(H)RP125	17.9 - 40.1																																																						
	PUHZ-RP140	20.1 - 45.9																																																						
	PUHZ-RP200	27.3 - 64.2																																																						
	PUHZ-HRP200	28.7 - 68.9																																																						
	PUHZ-RP250	32.1 - 80.3																																																						
	PUHZ-SW40	5.0 - 11.8																																																						
	PUHZ-SW50	7.0 - 17.2																																																						
	PUHZ-SW75	10.2 - 22.9																																																						
	PUHZ-SW100	14.4 - 32.1																																																						
	PUHZ-SW120	20.1 - 45.9																																																						
	PUHZ-SW175	27.3 - 64.2																																																						
	PUHZ-SW190	32.1 - 80.3																																																						
	PUHZ-SHW80	10.2 - 22.9																																																						
	PUHZ-SHW112	14.4 - 32.1																																																						
	PUHZ-SHW140	17.9 - 40.1																																																						
PUHZ-SHW230	28.7 - 68.9																																																							

Continue to the next page.

3. System

From the previous page.

Parts name	Requirement
Water circulation pump	<p>(1) Packaged-type units</p> <p>■ Heating</p> <div style="display: flex; justify-content: space-around;"> <div data-bbox="316 293 874 566"> <p>PUHZ-W50</p> </div> <div data-bbox="922 293 1481 566"> <p>PUHZ-W85</p> </div> </div> <div style="display: flex; justify-content: space-around; margin-top: 20px;"> <div data-bbox="316 584 874 857"> <p>PUHZ-HW112/140</p> </div> </div> <p>(2) Split-type units</p> <p>■ Heating</p> <div style="display: flex; justify-content: space-around; margin-top: 20px;"> <div data-bbox="316 1021 874 1294"> <p>PUHZ-RP35/50 *1 PUHZ-SW40/50</p> </div> <div data-bbox="922 994 1481 1294"> <p>PUHZ-RP60/71 *2 PUHZ-HRP71 *3 PUHZ-SW75 *2 PUHZ-SHW80 *2</p> </div> </div> <div style="display: flex; justify-content: space-around; margin-top: 20px;"> <div data-bbox="316 1312 874 1608"> <p>PUHZ-RP100/125/140 *3 PUHZ-HRP100/125 *3 PUHZ-SW100/120 *3 PUHZ-SHW112/140 *3</p> </div> <div data-bbox="922 1312 1481 1608"> <p>PUHZ-RP200/250 *4 PUHZ-HRP200 *4 PUHZ-SW175/190 *4 PUHZ-SHW230 *4</p> </div> </div> <p>*1 When the connected plate heat exchanger is ACH 30-30 made by ALFA LAVAL. *2 When the connected plate heat exchanger is ACH 70-30 made by ALFA LAVAL. *3 When the connected plate heat exchanger is ACH 70-40 made by ALFA LAVAL. *4 When two ACH 70-40 plate heat exchangers made by ALFA LAVAL are parallel-connected.</p>

3. System

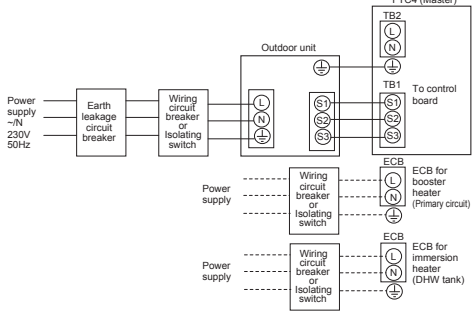
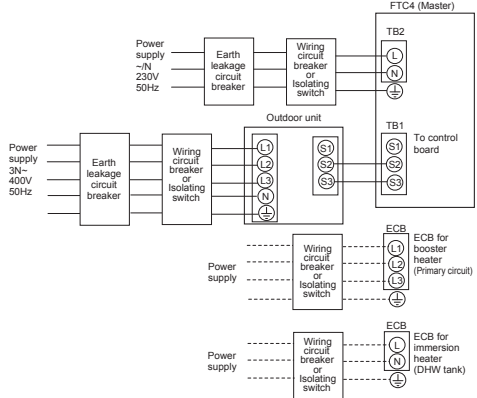
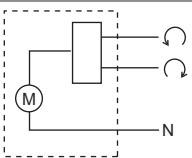
Parts name	Requirement																						
Booster heater	<p>General</p> <p>* Consider necessity and capacity of booster heater to meet the following points. (1) Heating capacity and flow water temperature should always be sufficient. (2) System can increase the temperature of the stored water in tank to inhibit legionella bacterium growth. (Note) System without neither booster heater or immersion heater, 'Legionella Prevention Mode' is NOT available. (3) Water circuit should not be frozen during defrost operation.</p>																						
	<p>Control Power for Contactor</p> <p>Current: 0.5A Max , Power supply: 230V AC * Use a relay.</p>																						
	<p>Separate power for Heater</p> <p>Install an earth leakage circuit breaker (ECB) for heater, separate from control power (See Fig.1 and Fig.2). * When using two booster heaters, booster heater 1 capacity must be less than that of booster heater 2. When using a single booster heater, connect to BH1 (TBO.3 1-2 (OUT6)) , and turn the Dip SW2-3 to ON. (Booster heater capacity restriction)</p>																						
	<div style="display: flex; justify-content: space-around;"> <div style="text-align: center;">  <p><Fig. 1 (1 phase)></p> </div> <div style="text-align: center;">  <p><Fig. 2 (3 phase)></p> </div> </div> <p>Heater capacity/Breaker/wiring (recommended)</p> <p><1 Phase></p> <table border="1" style="width: 100%; border-collapse: collapse;"> <thead> <tr> <th>Description</th> <th>Power supply</th> <th>Total capacity (BH1 + BH2)</th> <th>Breaker</th> <th>Wiring</th> </tr> </thead> <tbody> <tr> <td rowspan="2">Booster heater (Primary circuit)</td> <td rowspan="2">~N 230V 50Hz</td> <td>2 kW (2 kW + 0 kW)</td> <td>16 A</td> <td>2.5 mm²</td> </tr> <tr> <td>6 kW (2 kW + 4 kW)</td> <td>32 A</td> <td>6.0 mm²</td> </tr> </tbody> </table> <p><3 Phase></p> <table border="1" style="width: 100%; border-collapse: collapse;"> <thead> <tr> <th>Description</th> <th>Power supply</th> <th>Total capacity (BH1 + BH2)</th> <th>Breaker</th> <th>Wiring</th> </tr> </thead> <tbody> <tr> <td>Booster heater (Primary circuit)</td> <td>3~ 400V 50Hz</td> <td>9 kW (3 kW + 6 kW)</td> <td>16 A</td> <td>2.5 mm²</td> </tr> </tbody> </table> <p>* When installing a booster heater with the capacity of bigger than shown above, select an appropriate size breaker and cable (diameter) based on the maximum possible electric current.</p>	Description	Power supply	Total capacity (BH1 + BH2)	Breaker	Wiring	Booster heater (Primary circuit)	~N 230V 50Hz	2 kW (2 kW + 0 kW)	16 A	2.5 mm ²	6 kW (2 kW + 4 kW)	32 A	6.0 mm ²	Description	Power supply	Total capacity (BH1 + BH2)	Breaker	Wiring	Booster heater (Primary circuit)	3~ 400V 50Hz	9 kW (3 kW + 6 kW)	16 A
Description	Power supply	Total capacity (BH1 + BH2)	Breaker	Wiring																			
Booster heater (Primary circuit)	~N 230V 50Hz	2 kW (2 kW + 0 kW)	16 A	2.5 mm ²																			
		6 kW (2 kW + 4 kW)	32 A	6.0 mm ²																			
Description	Power supply	Total capacity (BH1 + BH2)	Breaker	Wiring																			
Booster heater (Primary circuit)	3~ 400V 50Hz	9 kW (3 kW + 6 kW)	16 A	2.5 mm ²																			
Safety device	<p>(1) Use an overheat protection thermostat (manual reset type) (to detect unusual temperature increase/heating up without water). Protection device operating temperature must be above 80 °C. Protection device should not operate quickly, but water circuit must not boil even when heater(s) overshoot. (Reference value) Thermostat operation temperature used in our Cylinder unit and Hydrobox : 90 °C ± 4 °C</p> <p>(2) Connect a pressure relief valve on the primary circuit side.</p>																						
Immersion heater	<p>General</p> <p>* Consider necessity and capacity of immersion heater to meet the following points. (1) Heating capacity and flow water temperature should always be sufficient. (2) System can increase the temperature of the stored water in tank to inhibit legionella bacterium growth. (Note) System without neither booster heater or immersion heater can not select 'Legionella Prevention Mode'.</p>																						
	<p>Control Power for Contactor</p> <p>Current: 0.5A Max , Power supply: 230V AC * Use a relay.</p>																						
	<p>Separate power for heater</p> <p>Install an earth leakage circuit breaker (ECB) for heater, separate from control power (See Fig.1 and Fig.2). *ECB is built-in in PAC-IF052B-E. Heater capacity/Breaker/wiring (recommended)</p> <p><1 Phase></p> <table border="1" style="width: 100%; border-collapse: collapse;"> <thead> <tr> <th>Description</th> <th>Power supply</th> <th>Capacity</th> <th>Breaker</th> <th>Wiring</th> </tr> </thead> <tbody> <tr> <td>Immersion heater (DHW tank)</td> <td>~N 230V 50Hz</td> <td>3 kW</td> <td>16 A</td> <td>2.5 mm²</td> </tr> </tbody> </table> <p>* When installing an immersion heater with the capacity of bigger than shown above, select an appropriate size breaker and cable (diameter) based on the maximum possible electric current.</p>	Description	Power supply	Capacity	Breaker	Wiring	Immersion heater (DHW tank)	~N 230V 50Hz	3 kW	16 A	2.5 mm ²												
Description	Power supply	Capacity	Breaker	Wiring																			
Immersion heater (DHW tank)	~N 230V 50Hz	3 kW	16 A	2.5 mm ²																			
Safety device	<p>(1) Install the enclosed thermistor THW5 on the DHW tank. (Microcomputer detecting temperature for protection: 80 °C)</p> <p>(2) Use a built-in direct cut-off thermostat (manual reset type). Protection device operating temperature must be above 80 °C. Protection device should not operate quickly, but water circuit must not boil even when a heater overshoots. (Reference value) Thermostat operation temperature used in our Cylinder unit : 85 °C ± 5°C</p> <p>(3) Connect a pressure relief valve on the sanitary water side.</p>																						
Mixing valve	<p>Current: 0.1 A Max (If over 0.1 A you must use a relay) Power supply: 230V AC Connect earth cable, if there is one. Type: Refer to the right figure.</p> <div style="text-align: center;">  <p>Mixing valve</p> </div>																						
Expansion Vessel (Primary circuit side) Expansion Vessel (Sanitary water side)	<p>When the water circuit is closed, select the expansion vessel according to water quantity of the water circuit. * Follow the national regulations.</p>																						
Limits of TOTAL electric current when connecting field supply parts	<p>Option 1. (Power supply from outdoor unit) TOTAL current requirement MUST be ≤ 3A (otherwise, the fuse on the outdoor unit PCB will blow).</p> <p>Option 2. (Independent power supply (i.e. from the FTC4 unit itself)) TOTAL current of the pump(s) MUST be ≤ 3A. The total current allowed for parts except pumps is ≤ 3A. (otherwise, the fuse on the FTC4 PCB will blow.)</p>																						

3. System

3.5 Local system

1-zone temperature control

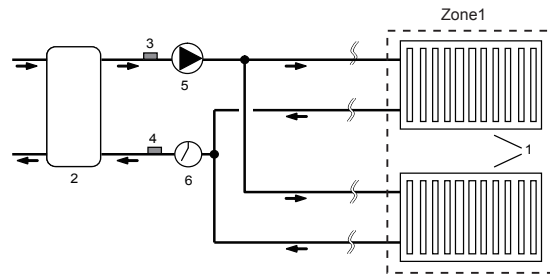
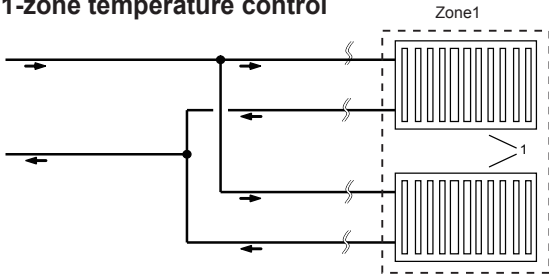

2-zone temperature control

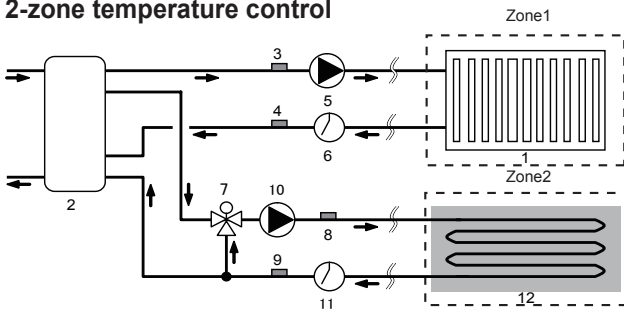

1-zone temperature control with boiler

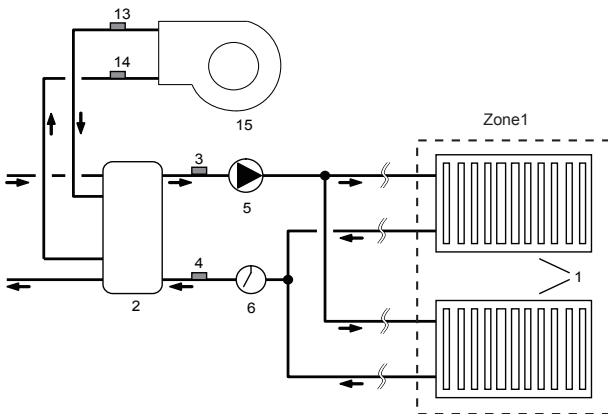

2-zone temperature control with boiler

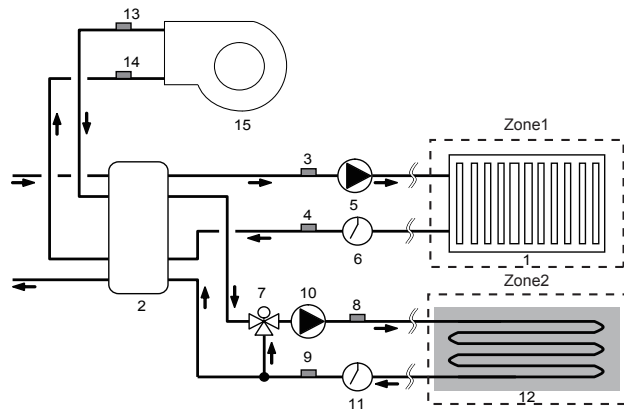

1. Zone1 heat emitters (e.g. radiator, fan coil unit) (field supply)
2. Mixing tank (field supply)
3. Zone1 flow water temp. thermistor (THW6) (option)
4. Zone1 return water temp. thermistor (THW7) (option)
5. Zone1 water circulation pump (field supply)
6. Zone1 flow switch (field supply)
7. Motorized mixing valve (field supply)
8. Zone2 flow water temp. thermistor (THW8) (option)

9. Zone2 return water temp. thermistor (THW9) (option)
10. Zone2 water circulation pump (field supply)
11. Zone2 flow switch (field supply)
12. Zone2 heat emitters (e.g. underfloor heating) (field supply)
13. Boiler flow water temp. thermistor (THWB1) (option)
14. Boiler return water temp. thermistor (THWB2) (option)
15. Boiler

Note: Cooling mode cannot run under 2-zone temperature control but can run both in Zone1 and Zone2 under 1-zone temperature control.

3.6 Piping diagram for 2-zone temperature control

The following component parts are required for piping for 2-zone control operation.

Arrange the following component parts.

- Mixing tank (field supply)
- Motorized mixing valve (field supply)
- Water circulation pump (x 2) (field supply)
- Flow switch (x 2) (field supply)
- Thermistor (x 4) *2 sets of (PAC-TH011-E) thermistors are required.

Wire the component parts to the water circuit referring to the figure below.

For more details on wiring, refer to "4.7 Wiring for 2-zone temperature controls".

Note: Do not install the thermistors on the mixing tank. This could affect correct monitoring of flow and return temperatures through each zone.

Install the Zone2 flow temp. thermistor (THW8) near the mixing valve.

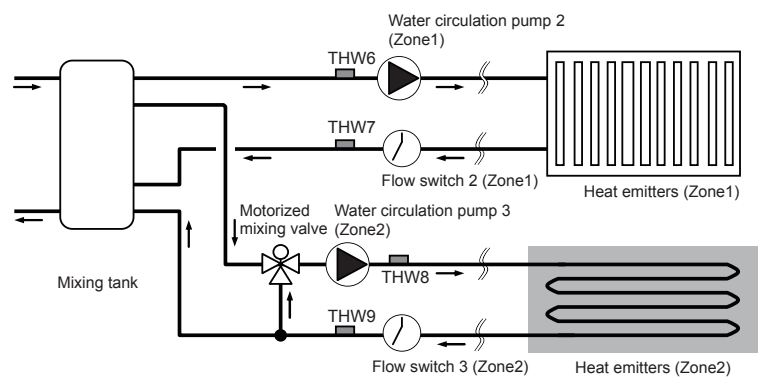

- Thermistor (THW6): Zone1 flow temp.
- Thermistor (THW7): Zone1 return temp.
- Thermistor (THW8): Zone2 flow temp.
- Thermistor (THW9): Zone2 return temp.

4. Electrical work

4.1 Electrical connection

All electrical work should be carried out by a suitably qualified technician. Failure to comply with this could lead to electrocution, fire, and death. It will also invalidate product warranty. All wiring should be according to national wiring regulations. For multiple outdoor units control with FTC4 (Slave), see section 9.

FTC4 (Master) can be powered in two ways.

1. Power cable is run from the outdoor unit to FTC4 (Master).
2. FTC4 (Master) has independent power source

Connections should be made to the terminals indicated in the following figures depending on the phase.

Breaker abbreviation	Meaning
ECB	Earth leakage circuit breaker for immersion heater
TB1	Terminal bed 1
TB2	Terminal bed 2

Immersion heater should be connected independently from one another to dedicated power supplies.

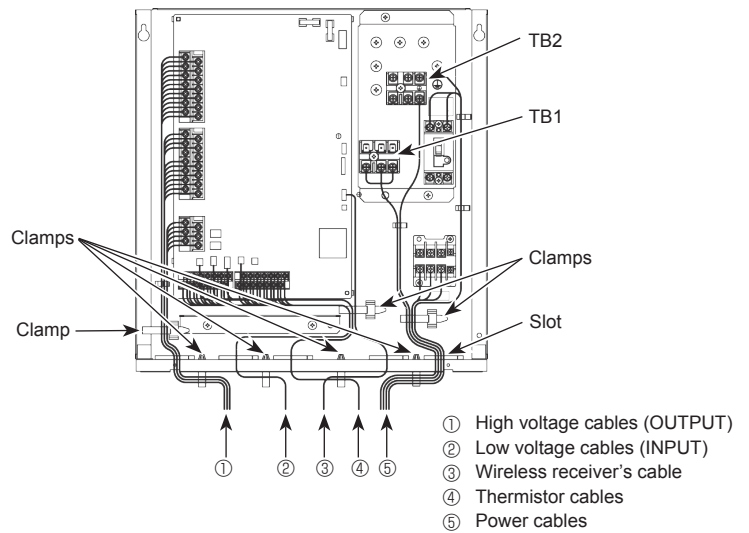

<Fig. 4.1.1> Wiring for PAC-IF052B-E

- Notes:
1. Do not run the low voltage cables through a slot that the high voltage cables go through.
 2. Do not run other cables through a slot that the wireless receiver's cable goes through.
 3. Do not bundle power cables together with other cables.
 4. Bundle cables as figure above by using clamps.

Option 1: FTC4 (Master) powered via outdoor unit

<1 phase>

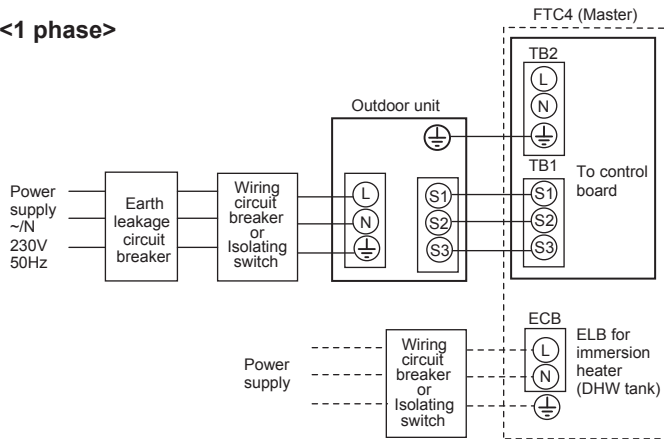

<3 phase>

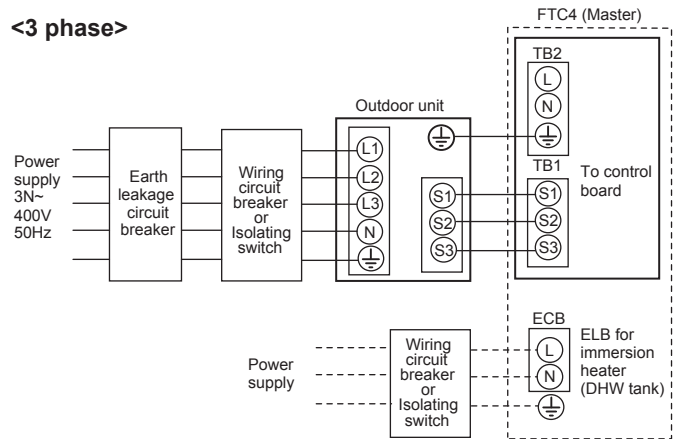

<Fig. 4.1.2>

Electrical connections 1 phase/3 phase

□ : PAC-IF051B-E
 □ : PAC-IF052B-E

*1 If the installed earth leakage circuit breaker does not have an over-current protection function, install a breaker with that function along the same power line.

*2 Affix label A that is included with the manuals near each wiring diagram for FTC4 (Master) and outdoor units.

Note: In accordance with IEE regulations the circuit breaker/isolating switch located on the outdoor unit should be installed with lockable devices (health and safety).

Wiring No. Wiring size (mm ²)	FTC4 (Master) - Outdoor unit	*2	3 × 1.5 (polar)
	FTC4 (Master) - Outdoor unit earth	*2	1 × Min. 1.5
Circuit rating	FTC4 (Master) - Outdoor unit S1 - S2	*3	AC230V
	FTC4 (Master) - Outdoor unit S2 - S3	*3	DC24V

*1. A breaker with at least 3.0 mm contact separation in each pole shall be provided. Use earth leakage breaker (NV). The breaker shall be provided to ensure disconnection of all active phase conductors of the supply.

*2. Max. 45 m

If 2.5 mm² used, Max. 50 m

If 2.5 mm² used and S3 separated, Max. 80 m

*3. The values given in the table above are not always measured against the ground value.

Notes: 1. Wiring size must comply with the applicable local and national codes.

2. FTC4 (Master)/outdoor unit connecting cords shall not be lighter than polychloroprene sheathed flexible cord. (Design 60245 IEC 57)
 FTC4 (Master) power supply cords shall not be lighter than polychloroprene sheathed flexible cord. (Design 60227 IEC 53)

3. Install an earth longer than other cables.

4. Please keep enough output capacity of power supply for each individual heater. Insufficient power supply capacity might cause chattering.

4. Electrical work

Option 2: FTC4 (Master) powered by independent source

If FTC4 (Master) and outdoor units have separate power supplies, the following requirements MUST be carried out:

- **FTC4 (Master) unit electrical box connector connections changed (see Fig. 4.1.3)**
- **Outdoor unit DIP switch settings changed to SW8-3 ON**
- **Turn on the outdoor unit before the FTC4 (Master).**

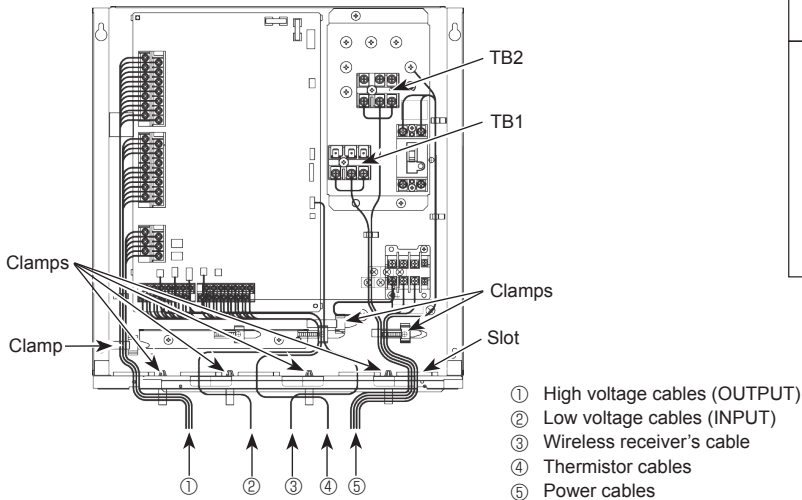

<Fig. 4.1.4> Wiring for PAC-IF052B-E

- Notes:
1. Do not run the low voltage cables through a slot that the high voltage cables go through.
 2. Do not run other cables through a slot that the wireless receiver's cable goes through.
 3. Do not bundle power cables together with other cables.
 4. Bundle cables as figure above by using clamps.

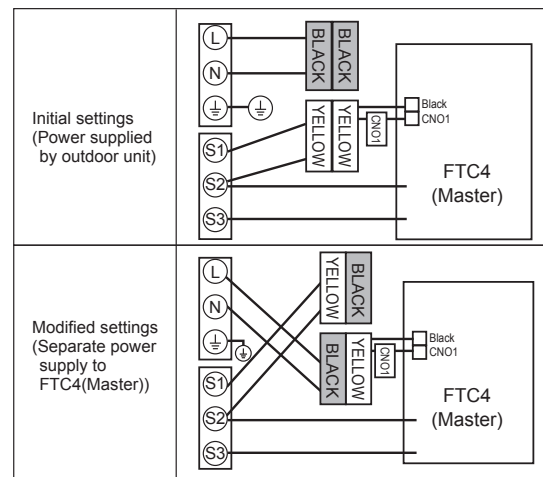

<Fig. 4.1.3>

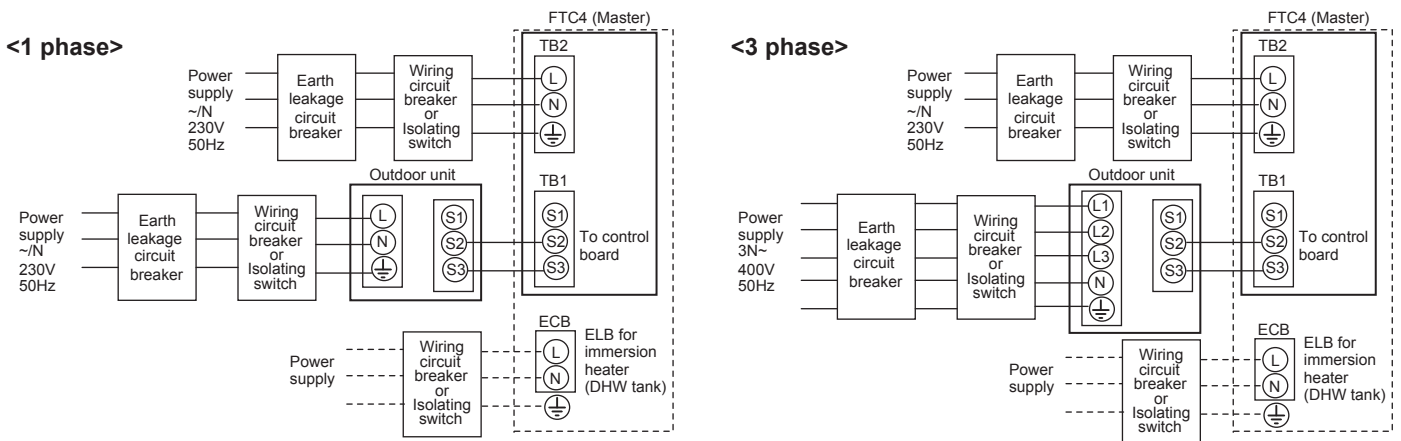

<Fig. 4.1.5>
Electrical connections 1 phase/3 phase

□ : PAC-IF051B-E
□ : PAC-IF052B-E

*1 If the installed earth leakage circuit breaker does not have an over-current protection function, install a breaker with that function along the same power line.

*2 Affix label B that is included with the manuals near each wiring diagram for FTC4 (Master) and outdoor units.

Note: In accordance with IEE regulations the circuit breaker/isolating switch located on the outdoor unit should be installed with lockable devices (health and safety).

FTC4 (Master) power supply		~N 230 V 50 Hz
FTC4 (Master) input capacity		*1 16 A
Main switch (Breaker)		
Wiring No. Wiring size (mm ²)	FTC4 (Master) power supply	2 × Min. 1.5
	FTC4 (Master) power supply earth	1 × Min. 1.5
	FTC4 (Master) - Outdoor unit	*2 2 × Min. 0.3
	FTC4 (Master) - Outdoor unit earth	—
Circuit rating	FTC4 (Master) L - N	*3 AC230V
	FTC4 (Master) - Outdoor unit S1 - S2	*3 —
	FTC4 (Master) - Outdoor unit S2 - S3	*3 DC24V

*1. A breaker with at least 3.0 mm contact separation in each pole shall be provided. Use earth leakage breaker (NV). The breaker shall be provided to ensure disconnection of all active phase conductors of the supply.

*2. Max. 120 m

*3. The values given in the table above are not always measured against the ground value.

- Notes:
1. Wiring size must comply with the applicable local and national codes.
 2. FTC4 (Master) unit/outdoor unit connecting cords shall not be lighter than polychloroprene sheathed flexible cord. (Design 60245 IEC 57) FTC4 (Master) unit power supply cords shall not be lighter than polychloroprene sheathed flexible cord. (Design 60227 IEC 53)
 3. Install an earth longer than other cables.
 4. Please keep enough output capacity of power supply for each individual heater. Insufficient power supply capacity might cause chattering.

4. Electrical work

4.2 Connecting the main controller

4.2.1 Connect the main controller cable to FTC4 (Master)

Connect the main controller cable to 11 and 12 on the terminal block (TBI. 2) on the FTC4 (Master) controller. <Fig. 4.2.1>

Wiring wire No. × size (mm²): 2 × 0.3 (non polar)

The 10 m wire is attached as an accessory. Max. 500 m

Wiring size must comply with the applicable local and national codes.

Circuit rating: 12V DC

Circuit rating is NOT always against the ground.

Location to place the main controller

When using the Remote controller options (refer to section 4.3), place the main controller on appropriate location that meets the following points to detect room temperature.

- Do not place the main controller in the periphery of a door or a window.
- Do not place the main controller near heat or cold sources, such as a radiator or the like.

Notes:

Wiring for main controller cable shall be (5 cm or more) apart from power source wiring so that it is not influenced by electric noise from power source wiring. (Do not insert main controller cable and power source wiring in the same conduit.) (Refer to Fig. 4.1.1)

When wiring to TBI.2, use the ring type terminals and insulate them from the cables of adjoining terminals.

4.2.2 Installing the main controller

1. The main controller can be installed either in the switch box or directly on the wall. Perform the installation properly according to the method.

(1) Secure clearances shown in <Fig. 4.2.2> regardless of whether installing the main controller either directly on the wall or in the switch box.

(2) Prepare the following items in the field.

- Double switch box
- Thin metal conduit
- Locknut and bushing
- Cable cover
- Wall plug

2. Drill an installation hole in the wall.

- Installation using a switch box
 - Drill a hole in the wall for the switch box, and install the switch box in the hole.
 - Fit the conduit tube into the switch box.

- Direct wall installation
 - Drill a cable access hole and thread the main controller cable through it.

⚠ Caution:

To prevent entry of dew, water, and insects, seal the gap between the cable and the hole through which the cable is threaded with putty. Otherwise, electric shock, fire, or failure may result.

3. Have the main controller ready.

Remove the back cover from the main controller.

4. Connect the main controller cable to the terminal block on the back cover.

Modify the main controller cable as shown in <Fig. 4.2.5>, and thread the cable from behind the back cover.

Completely thread the cable to the front so that the unsheathed part of the cable cannot be seen behind the back cover.

Connect the main controller cable to the terminal block on the back cover.

- Direct wall installation
 - Seal the gap between the cable and the hole through which the cable is threaded.

⚠ Caution

To prevent electric shock or failure, keep the sheath ends or any other foreign objects out of the terminal block.

Do not use ring terminals to connect the wires to the terminal block on the back cover. The terminals will come in contact with the control board and the cosmetic cover, which will result in failure.

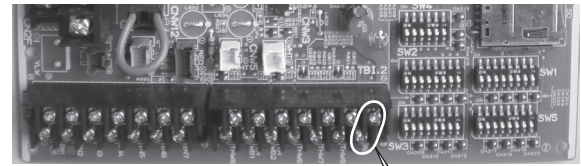

TBI.2 RC

<Fig. 4.2.1>

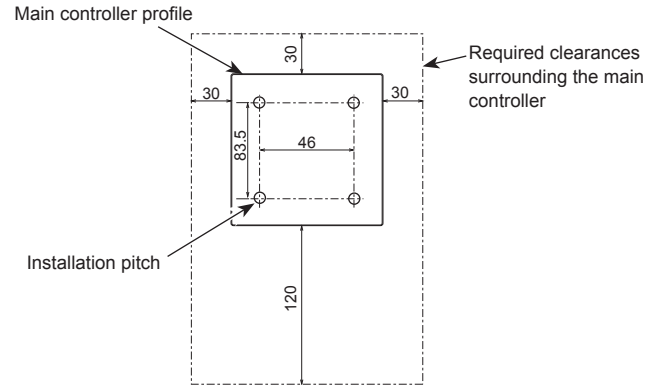

<Fig. 4.2.2>

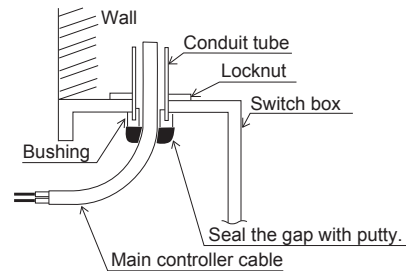

<Fig. 4.2.3>

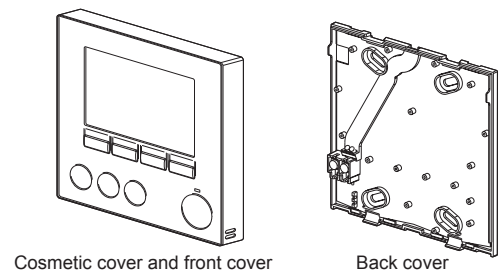

<Fig. 4.2.4>

Completely thread the unsheathed portion to the front.

The 2 inner wires must not be seen on the back.

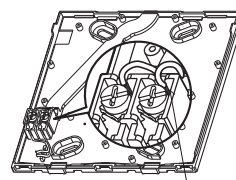
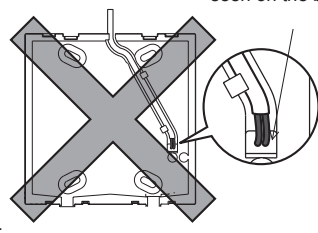
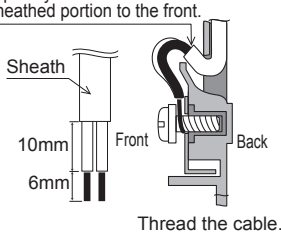

Connect the 2 inner wires to the terminal block (non polarized).

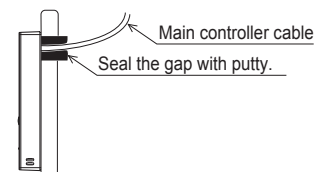

Thread the cable from behind the main controller.

<Fig. 4.2.5>

4. Electrical work

5. Install the back cover.

- Installation using a switch box
 - When installing the back cover in the switch box, secure at least two corners of the switch box with screws.

- Direct wall installation
 - Thread the cable through the slot provided.
 - When mounting the back cover on the wall, secure at least two corners of the main controller with screws.
 - To prevent the back cover from lifting, use top-left bottom-right corners of the main controller (viewed from the front) to secure the back cover to the wall with wall plugs or the like.

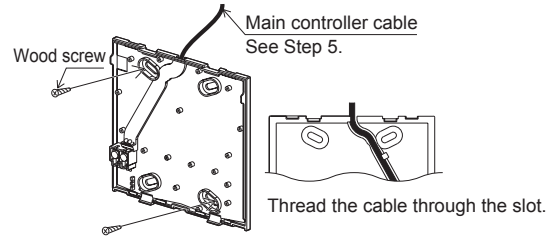
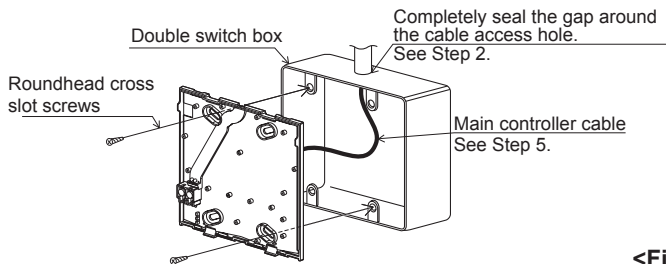

<Fig. 4.2.6>

⚠ Caution:

To avoid causing deformation or cracks to the main controller, do not overtighten the screws and make an additional installation hole(s).

6. Cut out the cable access hole.

- Direct wall installation
 - Cut out the knockout hole (indicated with grey in <Fig. 4.2.7>) in the cosmetic cover by knife or nipper.
 - Thread the main controller cable from the slot behind the back cover through this access hole.

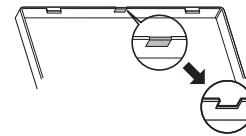

<Fig. 4.2.7>

7. Plug the lead wire cable into the front cover.

Plug the lead wire cable coming from the back cover into the front cover.

Securely plug the connector into the jack.

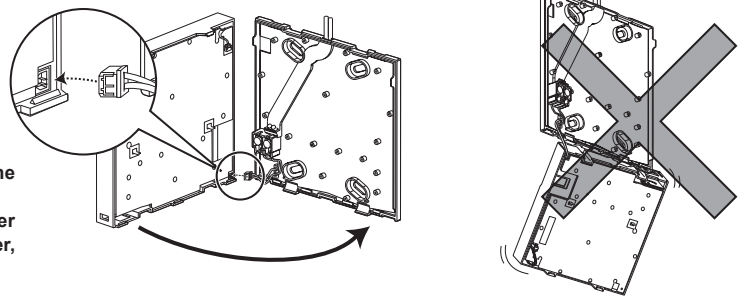

<Fig. 4.2.8>

⚠ Caution:

To avoid failures, do not remove the controller board protective sheet and the controller board from the front cover.

After the cable is plugged into the front cover, do not hang the front cover as shown in <Fig. 4.2.8>. Otherwise, the main controller cable could sever, which could cause malfunction to the main controller.

8. Fit the lead wires into the clamps.

⚠ Caution:

Hold the wires in place with clamps to prevent excessive strain from being applied on the terminal block and causing cable breakage.

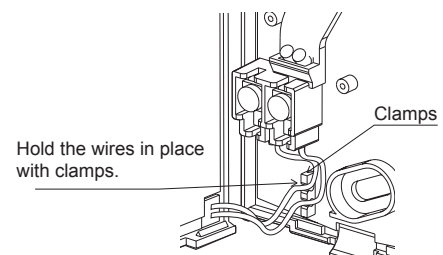

<Fig. 4.2.9>

4. Electrical work

9. Fit the front cover and the cosmetic cover onto the back cover.

The front cover assembly (fitted with the cosmetic cover at factory shipment) has two tabs on top. Hook the tabs onto the back cover and snap the front cover onto the back cover into place. Check that the cover is securely installed.

⚠ Caution:

When the front cover is correctly attached to the back cover a click is heard. If the cover is not clicked into place it may fall off.

- Direct wall installation (when routing the main controller cable along the wall surface)
 - Thread the main controller cable through the cable access hole at the top of the main controller.
 - Seal the gap between the cable and the access hole with putty.
 - Use a cable cover.

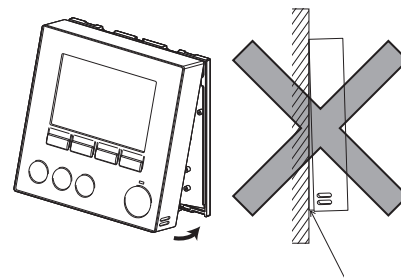

<Fig. 4.2.10>

Seal the gap between the cable and the access hole with putty. Use a cable cover.

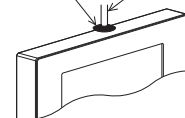

Thread the main controller cable through the cable access hole at the top of the main controller.

<Fig. 4.2.11>

● Disassembling the front cover and the cosmetic cover

(1) Remove the cosmetic cover.

Insert a flat head screwdriver into either of two open slots at the bottom of the main controller and move the screwdriver handle downward as shown. The engagement of the tabs will be released. Then pull the cosmetic cover toward the front to remove the cosmetic cover.

(2) Remove the front cover.

Insert a flat head screwdriver into either of two open slots at the bottom of the main controller. The subsequent procedure is the same as that of the cosmetic cover.

⚠ Caution:

Use a 5 mm- flat head screwdriver. Do not turn the screwdriver forcibly while placing the blade in the slots. Doing so could break the covers.

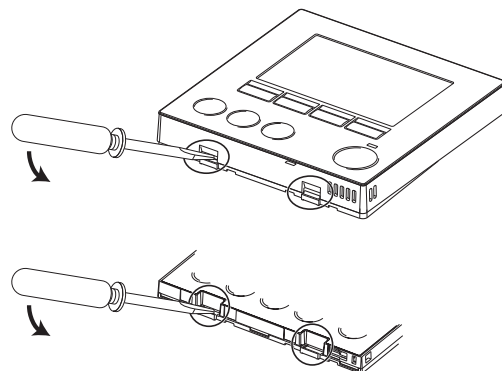

<Fig. 4.2.12>

4. Electrical work

4.3 Remote Controller Options

The FTC4 (cased) comes factory fitted with a main controller. This incorporates a thermistor for temperature monitoring and a graphical user interface to enable set-up, view current status and input scheduling functions. The main controller is also used for servicing purposes. This facility is accessed via password protected service menus.

To provide the best efficiency Mitsubishi Electric recommends using automatic adaptation function based on room temperature. To use this function a room thermistor needs to be present in a main living area. This can be done in a number of ways the most convenient are detailed below.

Refer to heating section of this manual for instructions on how to set compensation curve, flow temp or room temp (Auto adaptation).

For instructions on how to set the thermistor input for the FTC4 (Master) please refer to Initial settings section.

Factory supplied standard

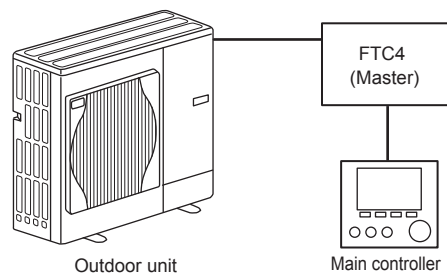

The factory setting for space heating mode is set to Room temp. (auto adaptation). If there is no room sensor present in the system, this setting must be changed to either Compensation curve mode or Flow temp mode.

Note: Auto-adaptation is not available in Cooling mode.

■ 1-zone temperature control

Control option A

This option features the main controller and the Mitsubishi Electric wireless remote controller. The wireless remote controller is used to monitor room temperature and can be used to make changes to the space heating settings, boost DHW (*1) and switch to holiday mode without having to directly use the main controller.

If more than one wireless remote controller is used, the most recently requested temperature setting will commonly be applied to all rooms by the central control system regardless of which wireless remote controller was used. No hierarchy exists across these remote controllers.

Wire the wireless receiver to FTC4 (Master) referring to the wireless remote controller instruction manual. **Turn DIP SW1-8 to ON.** Before operation configure the wireless remote controller to transmit and receive data referring to the wireless remote controller installation manual.)

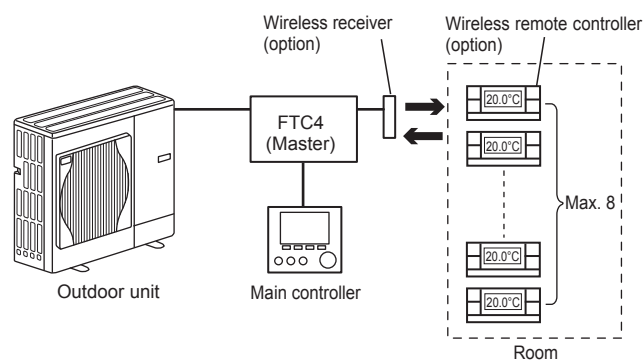

Control option B

This option features the main controller and the Mitsubishi Electric thermistor wired to FTC4 (Master). The thermistor is used to monitor room temperature but can not make any changes in control operation. Any changes to DHW (*1) must be made using the main controller mounted on the FTC4 (Master).

Wire the thermistor to the TH1 connector on FTC4 (Master).

The number of room temperature thermistors that can be connected to FTC4 (Master) is always one.

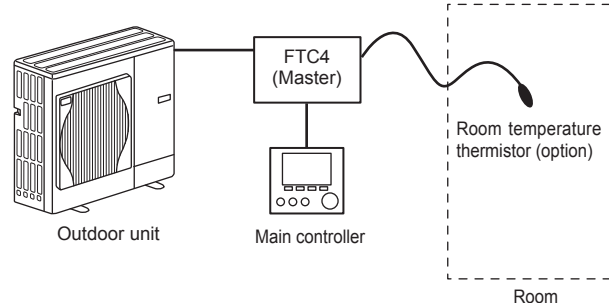

Control option C

This option features the main controller being removed from the FTC4 (Master) and situated in a different room. A thermistor built in the main controller can be used for monitoring the room temperature for Auto Adaptation function whilst keeping all its features of the main controller available.

The main controller and FTC4 (Master) are connected by a 2-core, 0.3 mm², non-polar cable (field supply) with a maximum length of 500 m.

To use the sensor in the main controller the main controller should come off from the FTC4 (Master). Otherwise it will detect the temperature of the FTC4 (Master) instead of room temperature. This will affect the output of the space heating.

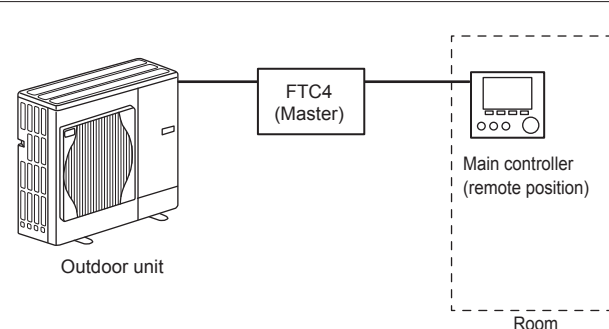

Control option D (Flow temp. or compensation curve only)

This option features the main controller and a locally supplied thermostat wired to FTC4 (Master). The thermostat is used to set the maximum temperature for heating room. Any changes to DHW (*1) must be made using main controller mounted on the FTC4 (Master).

The thermostat is wired to IN1 in TBI.1 on FTC4 (Master). The number of thermostats that can be connected to FTC4 (Master) is always one.

The wireless remote controller can be also used as a thermostat.

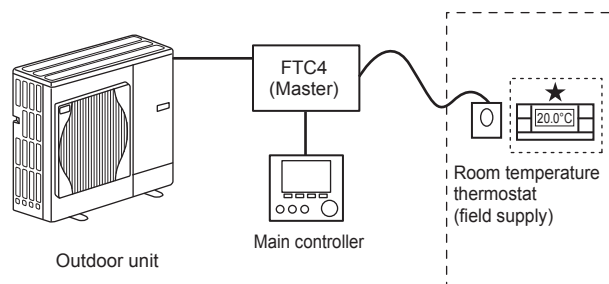

*1 If applicable

4. Electrical work

■ 2-zone temperature control

Control option A

This option features the main controller, the Mitsubishi Electric wireless remote controller and a locally supplied thermostat.

The wireless remote controller is used to monitor the Zone1 room temperature and the thermostat is used to monitor the Zone2 room temperature.

The thermostat can be also allocated to Zone1 and the wireless remote controller to Zone2.

The wireless remote controller can be also used to make changes to the space heating settings, boost DHW (*1) and switch to holiday mode without having to use the main controller.

If more than one wireless remote controller is used, the last temperature setting adjustment/demand will be applied to ALL rooms in same zone.

Wire the wireless receiver to FTC4 (Master) referring to the wireless remote controller instruction manual. Turn DIP SW1-8 to ON. Before operation configure the wireless remote controller to transmit and receive data referring to the wireless remote controller installation manual.)

The thermostat is used to set the maximum temperature for heating Zone2 room.

The thermostat is wired to IN6 on FTC4 (Master). (If the thermostat is allocated to Zone1, it is wired to IN1 on TBI.1.) (Refer to 4.5.)

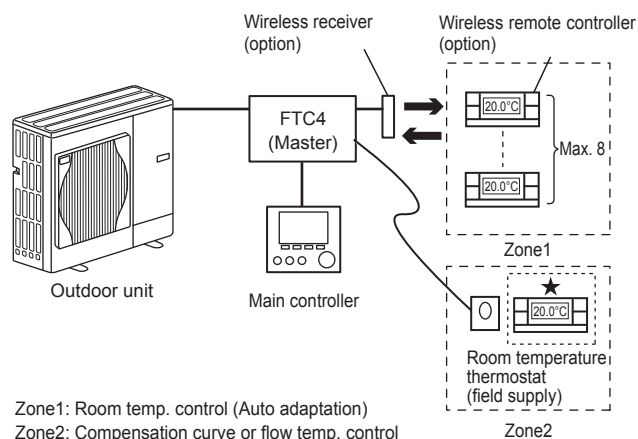

Control option B

This option features the main controller, the Mitsubishi Electric thermistor and a locally supplied thermostat that are wired to FTC4 (Master).

The thermistor is used to monitor the Zone1 room temperature and the thermostat is used to control the Zone2 room temperature.

The thermostat can be also allocated to Zone1 and the thermistor to Zone2.

The thermistor can not make any changes in control operation. Any changes to DHW (*1) must be made using the main controller mounted on the FTC4 (Master).

Wire the thermistor to the TH1 connector on FTC4 (Master).

The number of room temperature thermistors that can be connected to FTC4 (Master) is always one.

The thermostat is used to set the maximum temperature for heating Zone2 room.

The thermostat is wired to IN6 on FTC4 (Master). (If the thermostat is allocated to Zone1, wire it to IN1 on TBI.1.) (Refer to 4.5)

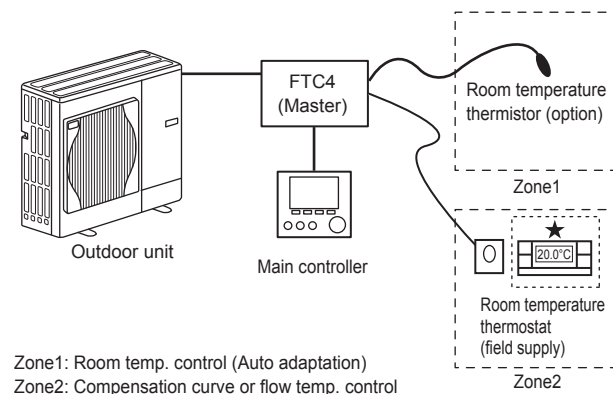

Control option C

This option features the main controller (with in-built thermistor) that is removed from the FTC4 (Master) to monitor the Zone1 room temperature and a locally supplied thermostat to monitor the Zone2 room temperature.

The thermostat can be also allocated to Zone1 and the thermistor to Zone2.

A thermistor built into the main controller can be used for monitoring the room temperature for Auto Adaptation function whilst keeping all its features of the main controller available.

The main controller and FTC4 (Master) are connected by a 2-core, 0.3 mm², non-polar cable (field supply) with a maximum length of 500 m.

To use the sensor in the main controller the main controller should be detached from the FTC4 (Master). Otherwise it will detect the temperature of the FTC4 (Master) instead of room temperature. This will affect the output of the space heating.

The thermostat is used to set the maximum temperature for heating Zone2 room.

The thermostat is wired to IN6 on FTC4 (Master). (If the thermostat is allocated to Zone1, wire it to IN1 on TBI.1.) (Refer to 4.5.)

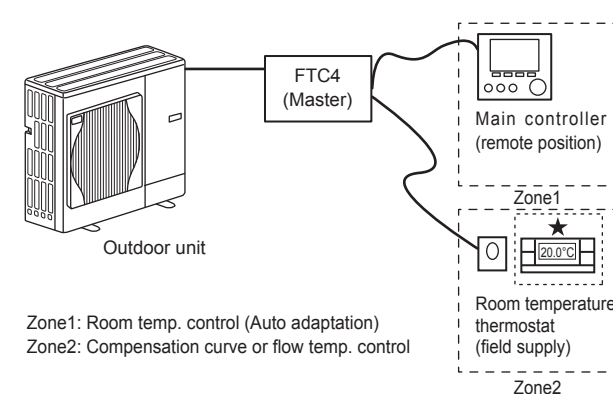

Control option D

This option features the locally supplied thermostats wired to FTC4 (Master). The thermostats are individually allocated to Zone1 and Zone2. The thermostats are used to set each maximum temperature for heating Zone1 and Zone2 rooms. Any changes to DHW (*1) must be made using the main controller mounted on the FTC4 (Master).

The thermostat for Zone1 is wired to IN1 in TBI.1 on FTC4 (Master).

The thermostat for Zone2 is wired to IN6 in TBI.1 on FTC4 (Master).

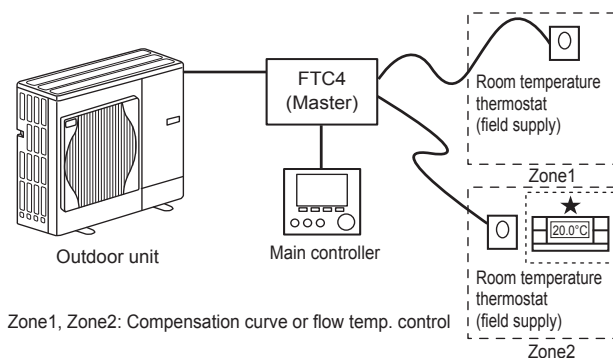

*1 If applicable

*2 For the options above, the sensor types can be exchanged between Zone1 and Zone2. (e.g. Wireless remote controller in Zone1 and Room temp thermostat in Zone2 can be changed to Room temp thermostat and wireless remote controller, respectively).

Also, the wireless remote controller can be used to function as a thermostat as well, if required.

4. Electrical work

4.4. Connecting the thermistor cables

Connect the thermistor for the FTC4 (Master) controller.

For multiple outdoor units control with FTC4 (Slave), see section 9.

4.4.1 Connecting the room temp. thermistor (TH1) cable

TH1 is an optional part (PAC-SE41TS-E).

TH1 is required to use the auto adaptation function. However, when room temperature detection is conducted by the main controller or the wireless remote controller (optional), this part is not required.

Connect the TH1 cable to the CN20 connector on FTC4 (Master).

When the TH1 cable is too long, bundle the excess cable outside the FTC4 (Master) unit. For more details, refer to Section 4.3 in this manual or the installation manual that comes with PAC-SE41TS-E.

When using TH1, place this sensor on appropriate location to detect room temperature.

4.4.2. Connecting the refrigerant pipe temp. thermistor (TH2) cable

Connect the TH2 cable to the CN21 connector on FTC4 (Master).

For split Outdoor unit : Connect TH2.

For packaged Outdoor unit : It is NOT necessary to connect TH2.

When the TH2 cable is too long, bundle the excess cable outside the FTC4 (Master) unit.

Do not bind the wires in the FTC4 (Master) unit.

<Thermistor position>

Place TH2 on **refrigerant** piping (**liquid** side).

It is recommended to protect the thermistor with heat insulating materials so as not to be affected by ambient temperature.

Note: Be sure to place TH2 where it correctly detects refrigerant piping temp. (liquid side).

Because;

- (1) TH2 is required to detect heating subcool correctly.
- (2) Refrigerant temperature of water-to-refrigerant heat exchanger also needs to be detected for protection purpose.

4.4.3. Connecting the flow water temp. thermistor (THW1) cable and the return water temp. thermistor (THW2) cable

The THW1 and the THW2 cables share a connector, and the connector connects to CNW12 connector on FTC4 (Master).

When the THW1 and THW2 cables are too long, bundle the excess cables outside the FTC4 (Master) unit.

Do not bind the wires in the FTC4 (Master) unit.

<Thermistor position>

Place THW1 on **water** piping (water **outlet** side) after booster heater, and THW2 on the water inlet side.

It is recommended to protect the thermistor with heat insulating materials so as not to be affected by ambient temperature.

Note: Be sure to attach THW1 where it correctly detects Flow temp. (water outlet side). For more details, see Page 6.

4.4.4. Connecting the actual DHW tank thermistor (THW5) cable

Connect the THW5 to the CNW5 connector on FTC4 (Master) if the DHW tank is available.

When the THW5 cable supplied with FTC4 (Master) is too long, bundle the excess cable outside the FTC4 (Master) unit.

Do not bind the wires in the FTC4 (Master) unit.

<Thermistor position>

Place THW5 on the position where tank water temperature can be detected correctly.

It is recommended to position the thermistor at the mid height of the DHW tank (to control DHW heating with this sensor).

It is recommended to protect the thermistor with heat insulating materials so as not to be affected by ambient temperature.

Especially for double (insulated) tank, thermistor should be attached to the inner side (to detect the water temperature).

Note:

Connect the terminals by using the ring terminals and also insulate the cables of adjoining terminals when wiring to TBI.1 or 2.

The necessary thermistor (THW6, THW7, THW8, THW9) connection for 2-zone temperature control, refer to “4.7 Wiring for 2-zone temperature control” .

The necessary thermistor (THWB1, THWB2, THW6, THW7) connection for back-up operation of boiler, refer to the installation manual of PAC-TH011HT-E .

⚠ Caution:

Do not route the thermistor cables together with power cables.

The sensor part of the thermistor should be installed where user can not access.

(It should be separated, by supplementary insulation, from areas the user can access.)

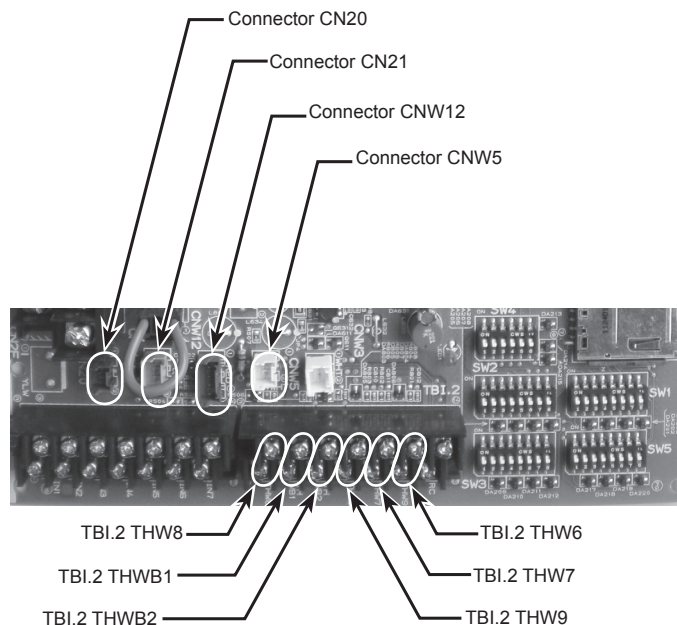

<Fig. 4.4.1>

4. Electrical work

4.4.5. Thermistor position and necessity

<Thermistor position and necessity>

Outdoor unit type	DHW tank	TH2	THW1	THW2	THW5
Split	Present	✓	✓	✓	✓
	Absent	✓	✓	✓	—
Packaged	Present	—	✓	✓	✓
	Absent	—	✓	✓	—

✓: Necessary. Connect the thermistor.

—: Not necessary. The thermistor is not required, do not connect.

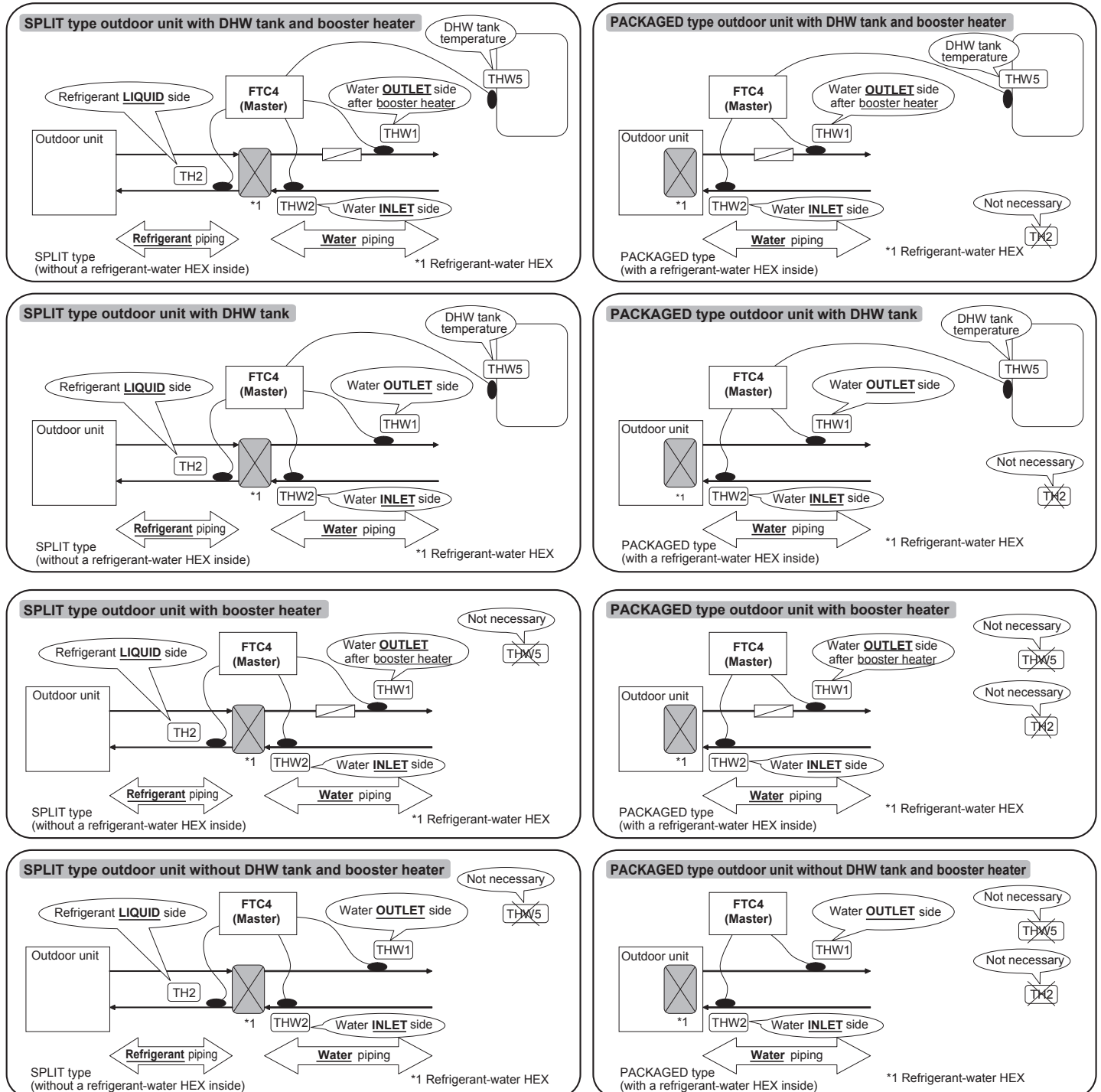

<Fig. 4.4.2>

4. Electrical work

4.5 Connecting inputs/outputs

For multiple outdoor units control with FTC4 (Slave), see section 9.

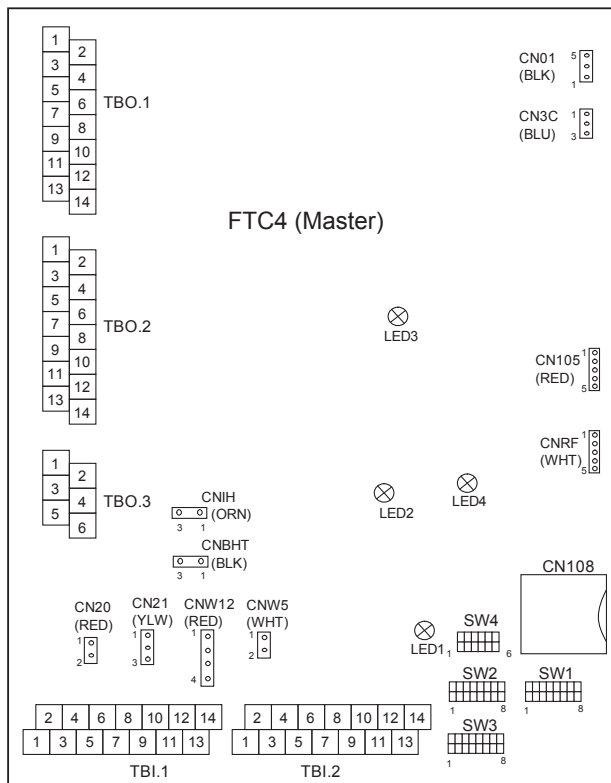

When the wires are wired to adjacent terminals use ring terminals and insulate the wires.

<Fig. 4.5.1>

4.5.1 Signal inputs

Name	Terminal block	Connector	Item	OFF (Open)	ON (Short)
IN1	TBI.1 1-2	—	Room thermostat 1 input	Refer to SW2-1 in <5.1 Dip Switch Functions>.	
IN2	TBI.1 3-4	—	Flow switch 1 input	Refer to SW2-2 in <5.1 Dip Switch Functions>.	
IN3	TBI.1 5-6	—	Flow switch 2 input (Zone1)	Refer to SW3-2 in <5.1 Dip Switch Functions>.	
IN4	TBI.1 7-8	—	Demand control input	Normal	Heat source OFF/ Boiler operation *2
IN5	TBI.1 9-10	—	Outdoor thermostat input (*1)	Standard operation	Heater operation/ Boiler operation *2
IN6	TBI.1 11-12	—	Room thermostat 2 input	Refer to SW3-1 in <5.1 Dip Switch Functions>.	
IN7	TBI.1 13-14	—	Flow switch 3 input (Zone2)	Refer to SW3-3 in <5.1 Dip Switch Functions>.	

*1. If using outdoor thermostat for controlling operation of heaters, the lifetime of the heaters and related parts may be reduced.

*2. To turn on the boiler operation, use the main controller to select "Boiler" in "External input setting" screen in the service menu.

Wiring specification and field supply parts

Item	Name	Model and specifications
Signal input function	Signal input wire	Use sheathed vinyl coated cord or cable. Max. 10 m Wire type: CV, CVS or equivalent Wire size: Stranded wire 0.5 mm ² to 1.25 mm ² Solid wire: ø0.65 mm to ø1.2 mm
	Switch	Non-voltage "a" contact signals Remote switch: minimum applicable load 12V DC, 1mA

4.5.2 Thermistor inputs

Name	Terminal block	Connector	Item	Optional part model
TH1	—	CN20	Thermistor (Room temp.) (Option)*1	PAC-SE41TS-E
TH2	—	CN21	Thermistor (Ref. liquid temp.)*2	—
THW1	—	CNW12 1-2	Thermistor (Flow water temp.)	—
THW2	—	CNW12 3-4	Thermistor (Return water temp.)	—
THW5	—	CNW5	Thermistor (DHW tank water temp.) (Option)*1	PAC-TH011TK-E
THW6	TBI.2 7-8	—	Thermistor (Zone1 flow water temp.) (Option)*1	PAC-TH011-E
THW7	TBI.2 9-10	—	Thermistor (Zone1 return water temp.) (Option)*1	PAC-TH011-E
THW8	TBI.2 1-2	—	Thermistor (Zone2 flow water temp.) (Option)*1	PAC-TH011-E
THW9	TBI.2 11-12	—	Thermistor (Zone2 return water temp.) (Option)*1	PAC-TH011-E
THWB1	TBI.2 3-4	—	Thermistor (Boiler flow water temp.) (Option)*1	PAC-TH011HT-E
THWB2	TBI.2 5-6	—	Thermistor (Boiler return water temp.) (Option)*1	PAC-TH011HT-E

Do not splice the wiring to extend or shorten it, or this could affect correct monitoring of each temperature.

If the wiring is too long, bundle it with a strap to adjust the length.

*1. The maximum length of the thermistor wiring is 5 m.

When the wires are wired to adjacent terminals, use ring terminals and insulate the wires.

*2. Except PAC-IF052B-E

4. Electrical work

4.5.3 Outputs

Name	Terminal block	Connector	Item	OFF	ON	Signal/Max current	Max. total current
OUT1	TBO.1 3-4	—	Water circulation pump 1 output (Space heating & DHW)	OFF	ON	230V AC 1.0 A Max	3.0 A (a)
OUT2	TBO.1 5-6	—	Water circulation pump 2 output (Space heating for Zone1)	OFF	ON	230V AC 1.0 A Max	
OUT3	TBO.1 7-8	—	Water circulation pump 3 output (Space heating for Zone2)	OFF	ON	230V AC 1.0 A Max	
OUT4	TBO.1 9-11	—	3-way valve (2-way valve 1) output	Heating	DHW	230V AC 0.1 A Max	3.0 A (b)
OUT5	TBO.1 12-13	—	Mixing valve output	Stop	Close	230V AC 0.1 A Max	
	TBO.1 13-14			Stop	Open		
OUT6	TBO.3 1-2	—	Booster heater 1 output	OFF	ON	230V AC 0.5 A Max (Relay)	
OUT7	TBO.3 3-4	—	Booster heater 2 output	OFF	ON	230V AC 0.5 A Max (Relay)	
OUT8	TBO.2 11-12	—	Booster heater 2+ output	OFF	ON	230V AC 0.5 A Max (Relay)	
OUT9	TBO.2 9-10	CNIH	Immersion heater output	OFF	ON	230V AC 0.5 A Max (Relay)	
OUT11	TBO.2 1-2	—	Error output	Normal	Error	230V AC 0.5 A Max	
OUT12	TBO.2 3-4	—	Defrost output	Normal	Defrost	230V AC 0.5 A Max	
OUT13	TBO.2 7-8	—	2-way valve 2 output	DHW	Heating	230V AC 0.1 A Max	
BC	TBO.3 5-6	—	Booster heater protection output	OFF (BHT open)	ON (BHT short)	230V AC 0.5 A Max	
OUT10	TBO.1 1-2	—	Boiler output	OFF	ON	non-voltage contact • 220 - 240V AC (30V DC) 0.5A or less • 10 mA 5V DC or more	—
BHT	TBO.2 13-14	CNBHT	Thermostat for booster heater	Thermostat Normal: short / High temp.: open			

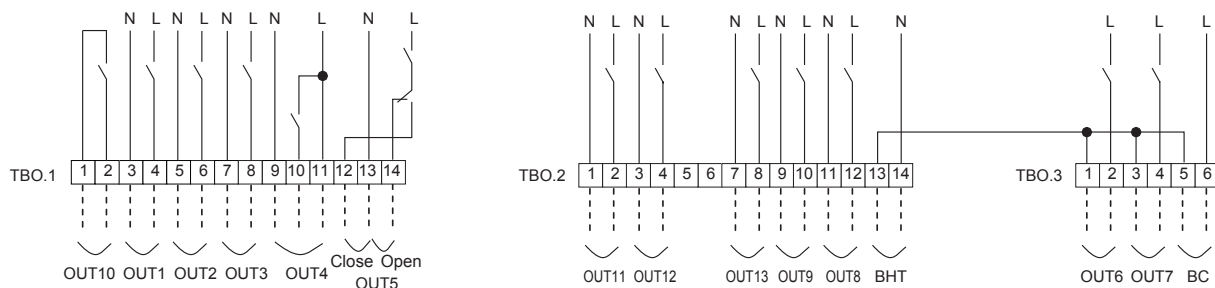

Wiring specification and field supply parts

Item	Name	Model and specifications
External output function	Outputs wire	Use sheathed vinyl coated cord or cable. Max. 30 m Wire type: CV, CVS or equivalent Wire size: Stranded wire 0.5 mm ² to 1.25 mm ² Solid wire: ø0.65 mm to ø1.2 mm

Note:

1. When the hydrobox is powered via outdoor unit, the maximum grand total current of (a)+(b) is 3.0 A.
2. Do not connect multiple water circulation pumps directly to each output (OUT1, OUT2, and OUT3). In such a case, connect them via (a) relay(s).
3. Connect an appropriate surge absorber to OUT10 (TBO.1 1-2) depending on the load at site.

4. Electrical work

4.6 Wiring for heater

<Care to be taken when connecting a booster heater(s)>

The initial setting assumes that the connected booster heater(s) has a built-in direct cut-off thermostat. <Fig. 4.6.1>

When the connected booster heater(s) has a built-in indirect cut-off thermostat, perform wiring according to the following items. < Fig. 4.6.2>

- Connect the thermostat signal to BHT (TBO.2 13-14).
- Remove the jumper wire from connector CNBHT.
- Connect a contactor (or relay) for protecting the booster heater.
(Connect the electromagnetic coil terminals to BC (TBO.3 5-6).

* Do not remove the jumper wire from connector CNBHT when the connected booster heater(s) has a built-in direct cut-off thermostat. < Fig. 4.6.1>

<Care to be taken when connecting an immersion heater>

The initial setting assumes that the connected immersion heater has a built-in direct cut-off thermostat. <Fig. 4.6.3>

<Wiring for booster heater with a built-in direct cut-off thermostat>

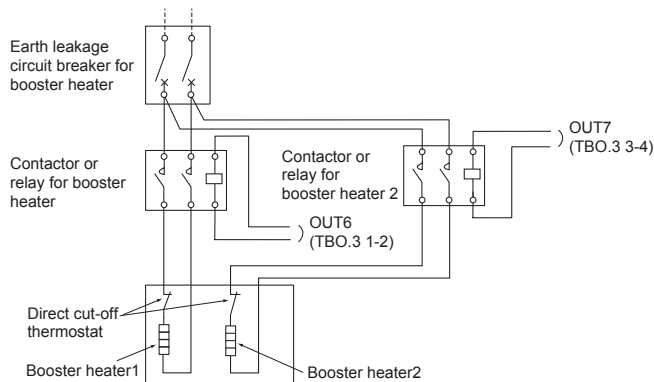

<Fig. 4.6.1>

<Wiring for booster heater with a built-in indirect cut-off thermostat>

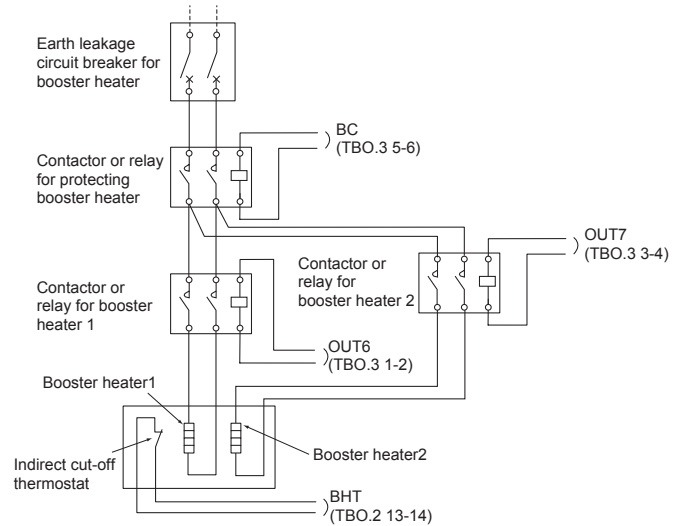

<Fig. 4.6.2>

<Wiring for immersion heater with a built-in direct cut-off thermostat>

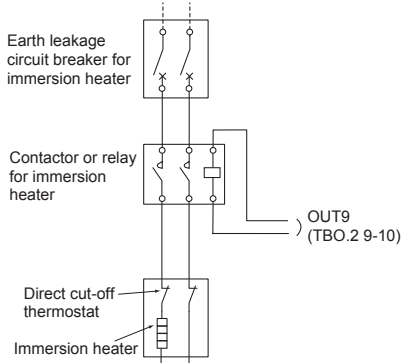

<Fig. 4.6.3>

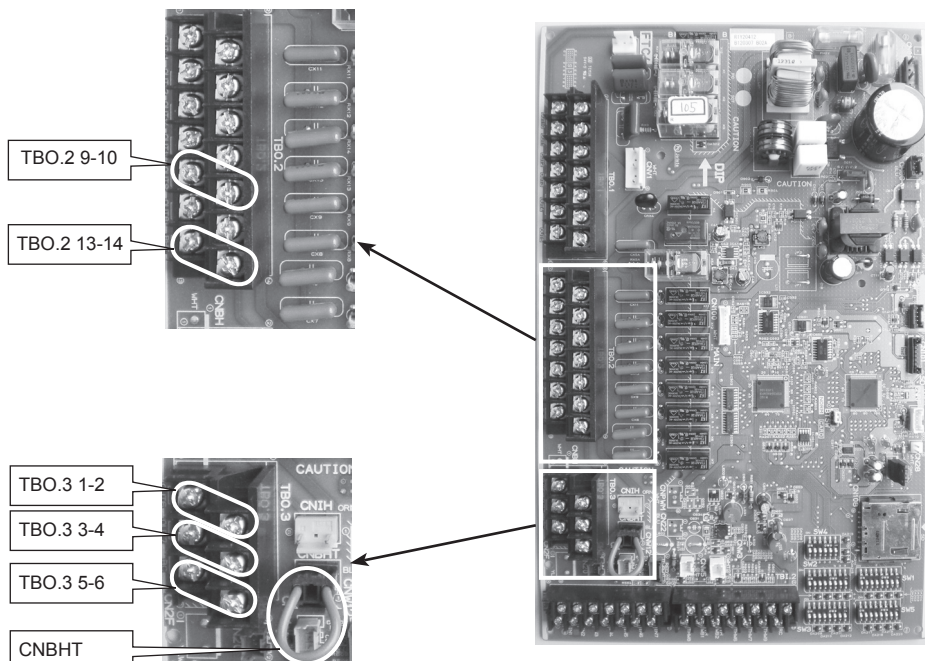

4. Electrical work

4.7 Wiring for 2-zone temperature control

1. Water circulation pump 2 (Zone1 water circulation pump) / Water circulation pump 3 (Zone2 water circulation pump)

Electrically wire water circulation pumps 2 and 3 to the appropriate output terminals. (Refer to "Outputs" in 4.5.)

2. Flow switch 2 (Zone1 flow switch) / Flow switch 3 (Zone2 flow switch)

Connect flow switches 2 and 3 to the appropriate terminals. (Refer to "Signal inputs" in 4.5.)

Set dip switches 3-2 and 3-3 according to the functions of individual flow switches 2 and 3. (Refer to "Dip switch setting" in 5.)

3. Thermistor

Connect the thermistor to monitor the Zone1 flow temp. to the THW6 (TBI. 2-7 and 2-8) terminals.

Connect the thermistor to monitor the Zone1 return temp. to the THW7 (TBI. 2-9 and 2-10) terminals.

Connect the thermistor to monitor the Zone2 flow temp. to the THW8 (TBI. 2-1 and 2-2) terminals.

Connect the thermistor to monitor the Zone2 return temp. to the THW9 (TBI. 2-11 and 2-12) terminals.

The maximum length of the thermistor wiring is 5 m. Do not splice the wiring to extend or shorten it, or this could affect correct monitoring of each hot water temperature through zones.

If the wiring is too long, bundle it with a strap to adjust the length.

4. Motorized mixing valve

Connect three wires coming from the motorized mixing valve to the appropriate terminals referring to "Outputs" in 5.2.

Note: Connect the signal line to open Port A (hot water inlet port) to TBO. 1-14 (Open), the signal line to open Port B (cold water inlet port) to TBO. 1-12 (Close), and the neutral terminal wire to TBO. 1-13 (N).

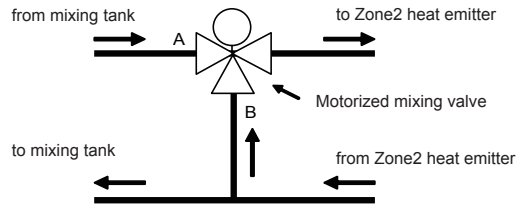
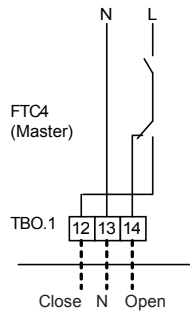

4. Electrical work

4.8 Installation procedure for DHW tank

Note:

- Be aware that the respective DHW operations are greatly effected by the selections of the components such as tank, immersion heater, or the like.
- Follow your local regulations to perform system configuration.

1. To enable switching of the water circulation circuit between the DHW mode and the heating mode, install a 3-way valve (field supply). The 3-way valve and the DHW tank should be positioned as shown in the system diagram in section 3. The use of two 2-way valves can perform the same function as a 3-way valve.

2. Install the optional thermistor THW5 (optional part PAC-TH011TK-E) on the DHW tank.

It is recommended to position the thermistor at the mid point of the DHW tank capacity. Insulate thermistor from ambient air. Especially for double (insulated) tank, thermistor should be attached to the inner side (to detect the water temperature).

3. Connect the thermistor lead to the CNW5 connector on the FTC4 (Master). If the thermistor lead is too long bundle it with a strap to adjust the length.

4. The output terminals for the 3-way valve is TBO.1 9-11 (OUT4). The TBO.1 9-11 terminals on the FTC4 (Master) are shown in the wiring diagram on the page 20.

Choose the terminals that the 3-way valve is connected to between TBO.1 9-10, or TBO.1 9-11, according to the rated voltage.

When the rated current of the 3-way valve exceeds 0.1A, be sure to use a relay with maximum voltage and current ratings of 230V AC / 0.1A when connecting to the FTC4 (Master). Do not directly connect the 3-way valve cable to the FTC4 (Master). Connect the relay cable to the TBO.1 9-10 terminals.

3-way valve must be of SPST type. SPDT type can NOT be used.

For systems using 2-way valves instead of a 3-way valve please read the following;

Specification of 2-way valve (field supply)

- Power supply: 230V AC
- Current: 0.1A Max (If over 0.1A you must use a relay)
- Type: Normally closed

	Installation position	Electrical connection terminal block	Output signal		
			Heating	DHW	System OFF
2-way valve1	DHW	TBO.1 9-10	OFF (closed)	ON (open)	OFF (closed)
2-way valve2	Heating	TBO.2 7-8	ON (open)	OFF (closed)	OFF (closed)

Note: Should the 2-way valve become blocked the water circulation will stop.

A by-pass valve or circuit should be installed between pump and 2-way valve for safety.

The TBO.2 7-8 terminals on the FTC4 (Master) are shown in the wiring diagram. The 2-way valve (field supply) should be installed according to the instructions supplied with it. Follow 2-way valve's manufacturer's instructions as to whether to connect an earth cable or not.

- For the 2-way valve, choose the one that slowly opens and shuts off to prevent water hammer sound.
- Choose the 2-way valve equipped with manual override, which is necessary for topping up or draining of water.

5. Turn the DIP SW1-3 on the FTC4 (Master) to ON.

6. When using an immersion heater (field supply), connect a contact relay cable for the immersion heater to TBO.2 9-10 (OUT9), and turn the Dip SW1-4 to ON. Do NOT directly connect the power cable to the FTC4 (Master).

Note:

- When an immersion heater is installed, select appropriate breaker capacity and a cable with appropriate diameter on the basis of heater output.
- When wiring an immersion heater in the field, always install an earth leakage breaker to prevent accidental electric shock.

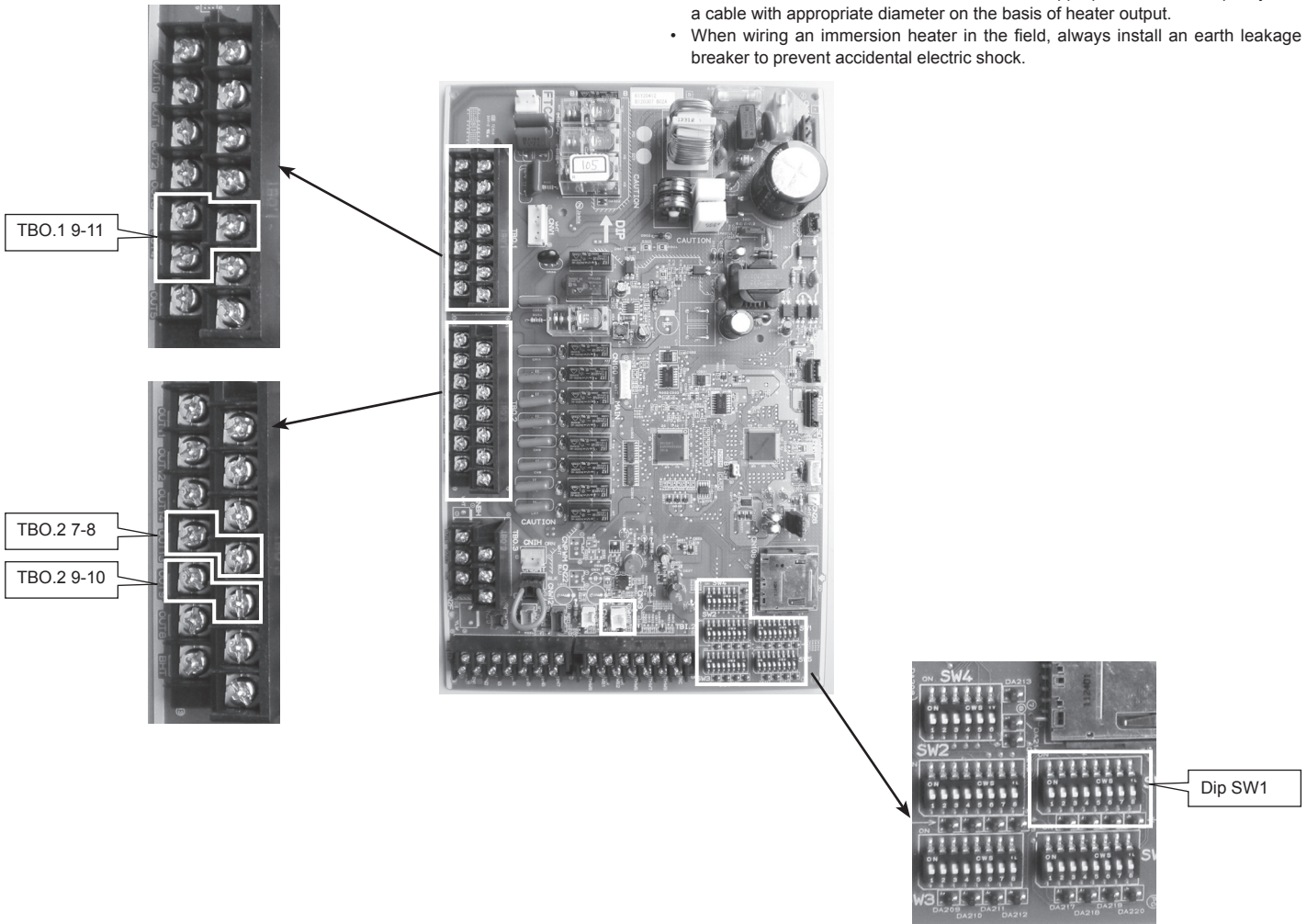

- ⚠ WARNING: When connecting DHW tank**
- (1) Attach the optional thermistor THW5 (PAC-TH011TK-E).
 - (2) Always use earth leakage breaker when connecting immersion heater.
 - (3) When installing an immersion heater, be sure that the immersion heater has a built-in direct cut-off thermostat.
 - (4) Connect a pressure relief valve on the sanitary water side.

4. Electrical work

4.9 Using SD memory card

FTC4 is equipped with an SD memory card interface. Using an SD memory card can simplify main controller settings and can store operating logs. *1

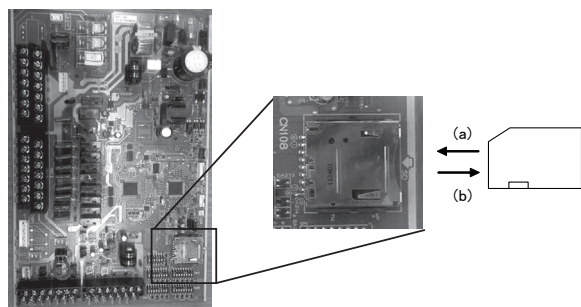

FTC4 (Master)

(a) For insertion, push on the SD memory card until it clicks into place.
 (b) For ejection, push on the SD memory card until it clicks.
Note: To avoid cutting fingers, do not touch sharp edges of the SD memory card connector (CN108) on the FTC4 control board.

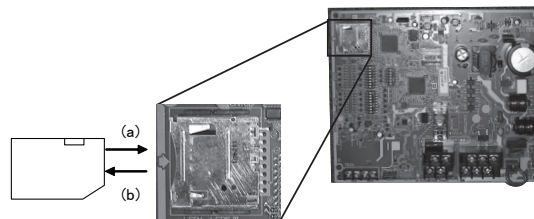

FTC4 (Slave)

<Handling precautions>

- (1) Use an SD memory card that complies with the SD standards. Check that the SD memory card has a logo on it of those shown to the right.
- (2) SD memory cards to the SD standards include SD, SDHC, miniSD, micro SD, and microSDHC memory cards. The capacities are available up to 32 GB. Choose that with a maximum allowable temperature of 55°C.
- (3) When the SD memory card is a miniSD, miniSDHC, microSD, or micro SDHC memory card, use an SD memory card converter adapter.
- (4) Before writing to the SD memory card, release the write-protect switch.

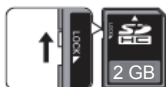

- (5) Before inserting or ejecting an SD memory card, make sure to power off the system. If an SD memory card is inserted or ejected with the system powered on, the stored data could be corrupted or the SD memory card be damaged. *An SD memory card is live for a whilst after the system is powered off. Before insertion or ejection wait until the LED lamps on the FTC4 control board are all off.
- (6) The read and write operations have been verified using the following SD memory cards, however, these operations are not always guaranteed as the specifications of these SD memory cards could change.

Manufacturer	Model	Tested in
Verbatim	#44015 0912-61	Mar. 2012
SanDisk	SDSDB-002G-B35	Oct. 2011
Panasonic	RP-SDP04GE1K	Oct. 2011
Arvato	2GB PS8032 TSB 24nm MLC	Jun. 2012

Before using a new SD memory card (including the card that comes with the unit), always check that the SD memory card can be safely read and written to by the FTC4 controller.

<How to check read and write operations>

- a) Check for correct wiring of power supply to the system. For more details, refer to section 4.1.
(Do not power on the system at this point.)
 - b) Insert an SD memory card.
 - c) Power on the system.
 - d) The LED4 lamp lights if the read and write operations are successfully completed. If the LED4 lamp continues blinking or does not light, the SD memory card cannot be read or written to by the FTC4 controller.
- (7) Make sure to follow the instruction and the requirement of the SD memory card's manufacturer.
 - (8) Format the SD memory card if determined unreadable in step (6). This could make it readable.
Download an SD card formatter from the following site.
SD Association homepage: <https://www.sdcard.org/home/>
 - (9) FTC4 supports FAT file system but not NTFS file system.
 - (10) Mitsubishi Electric is not liable for any damages, in whole or in part, including failure of writing to an SD memory card, and corruption and loss of the saved data, or the like. Back up saved data as necessary.
 - (11) Do not touch any electronic parts on the FTC4 control board when inserting or ejecting an SD memory card, or else the control board could fail.

Logos



Capacities

2 GB to 32 GB *2

SD speed classes

All

- The SD Logo is a trademark of SD-3C, LLC.
The miniSD logo is a trademark of SD-3C, LLC.
The microSD logo is a trademark of SD-3C, LLC.

*1 To edit main controller settings or to check operating data, an Ecodan service tool (for use with PC) is required.

*2 A 2-GB SD memory card stores up to 30 days of operation logs.

5. Dip Switch setting

5.1 Dip Switch Functions

Located on the FTC4 printed circuit board are 4 sets of small white switches known as Dip switches. The Dip switch number is printed on the circuit board next to the relevant switches. The word ON is printed on the circuit board and on the Dip switch block itself. To move the switch you will need to use a pin or the corner of a thin metal ruler or similar.

Dip switch settings are listed below.

Make sure to turn off both indoor unit and outdoor unit power supplies before changing the switch settings.

For multiple outdoor units control with FTC4 (Slave), see section 9.

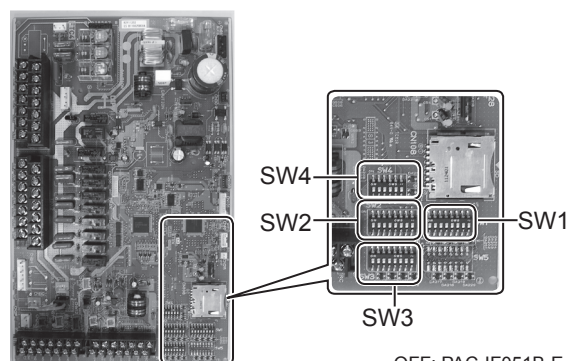

OFF: PAC-IF051B-E
PAC-SIF051B-E
ON: PAC-IF052B-E

Dip switch	Function	OFF	ON	Default settings: Indoor unit model	
SW1	SW1-1	Boiler	WITHOUT Boiler	WITH Boiler	OFF
	SW1-2	Heat pump maximum outlet water temperature	55°C	60°C	ON *1
	SW1-3	DHW tank	WITHOUT DHW tank	WITH DHW tank	OFF: PAC-IF051B-E PAC-SIF051B-E ON: PAC-IF052B-E
	SW1-4	Immersion heater	WITHOUT Immersion heater	WITH Immersion heater	OFF: PAC-IF051B-E PAC-SIF051B-E ON: PAC-IF052B-E
	SW1-5	Booster heater	WITHOUT Booster heater	WITH Booster heater	ON
	SW1-6	Booster heater function	For heating only	For heating and DHW	ON
	SW1-7	Outdoor unit type	Split type	Packaged type	OFF: PAC-IF051B-E PAC-SIF051B-E ON: PAC-IF052B-E
	SW1-8	Wireless remote controller	WITHOUT Wireless remote controller	WITH Wireless remote controller	OFF
SW2	SW2-1	Room thermostat1 input (IN1) logic change	Zone1 operation stop at thermostat short	Zone1 operation stop at thermostat open	OFF
	SW2-2	Flow switch1 input (IN2) logic change	Failure detection at short	Failure detection at open	ON
	SW2-3	Booster heater capacity restriction	Inactive	Active	OFF
	SW2-4	Cooling mode function	Inactive	Active	OFF
	SW2-5	Automatic switch to backup heat source operation (When outdoor unit stops by error)	Inactive	Active *2	OFF
	SW2-6	Mixing tank	WITHOUT Mixing tank	WITH Mixing tank	OFF
	SW2-7	2-zone temperature control	Inactive	Active	OFF
	SW2-8	—	—	-	OFF
SW3	SW3-1	Room thermostat 2 input (IN6) logic change	Zone2 operation stop at thermostat short	Zone2 operation stop at thermostat open	OFF
	SW3-2	Flow switch 2 input (IN3) logic change	Failure detection at short	Failure detection at open	OFF
	SW3-3	Flow switch 3 input (IN7) logic change	Failure detection at short	Failure detection at open	OFF
	SW3-4	Cooling operation in Zone2	Not in use	In use	OFF
	SW3-5	Heating mode function *3	Inactive	Active	OFF
	SW3-6	—	—	—	OFF
	SW3-7	—	—	—	OFF
	SW3-8	—	—	—	OFF
SW4	SW4-1	Multiple outdoor units control	Inactive	Active	OFF: PAC-IF051B-E PAC-IF052B-E ON : PAC-SIF051B-E
	SW4-2	Position of multiple outdoor units control *4	Slave	Master	OFF
	SW4-3	—	—	—	OFF
	SW4-4	—	—	—	OFF
	SW4-5	Emergency mode (Heater only operation)	Normal	"Emergency mode (Heater only operation) (To be activated only when powered ON)"	OFF *5
	SW4-6	Emergency mode (Boiler operation)	Normal	"Emergency mode (Boiler operation) (To be activated only when powered ON)"	OFF *5

Note: *1. When the FTC4 is connected with a PUHZ-RP outdoor unit of which maximum outlet water temperature is 55°C, Dip SW1-2 must be changed to OFF.

*2. OUT11 will be available. For safety reasons, this function is not available for certain errors. (In that case, system operation must be stopped and only the water circulation pump keeps running.)

*3 This switch functions only when the FTC4 is connected with a PUHZ-FRP outdoor unit. When another type of outdoor unit is connected, the heating mode function is active regardless of the fact that this switch is ON or OFF.

*4. SW4-2 is available only when SW4-1 is ON.

*5. If emergency mode is no longer required, return the switch to OFF position.

5. Dip Switch setting

5.2 Outdoor unit type

Set Dip SW 1-7 to set the outdoor unit type.

Dip SW 1-7	Setting	Note
OFF	Split type	Necessary to connect TH2
ON	Packaged type	Not necessary to connect TH2

Set Dip SW 1-2 to set the heat pump maximum outlet water temperature.

Dip SW 1-2	Setting
OFF	55 °C
ON	60 °C

When the outdoor unit is a PUHZ-RP series set the Dip SW 1-2 to ON, other than that, set the Dip SW 1-2 to OFF.

Note: When Dip SW 1-2 is OFF (55°C) and an electric heater is not installed (*), 'Legionella Prevention Mode' is NOT available.

* Dip SW settings set when no electric heater is installed.

Dip SW 1-2	Dip SW 1-4	Dip SW 1-5	Dip SW 1-6
OFF	OFF	ON	OFF
OFF	OFF	OFF	(ON/OFF)

5.3 Functions setting

Set Dip SW 1-3 to set whether the system has a DHW tank.

Dip SW 1-3	Setting	Note
OFF	WITHOUT DHW tank	Not necessary to connect THW5
ON	WITH DHW tank	Necessary to connect THW5

When Dip SW 1-3 is OFF, DHW mode is not available.

Set Dip SW 1-4 to set whether the system has an immersion heater.

Dip SW 1-4	Setting
OFF	WITHOUT immersion heater
ON	WITH immersion heater

Set Dip SW 1-5 to set whether the system has a booster heater.

Dip SW 1-5	Setting
OFF	WITHOUT booster heater
ON	WITH booster heater

Set Dip SW 1-6 to set the booster heater function.

Dip SW 1-6	Setting
OFF	For heating only
ON	For heating and DHW

Set Dip SW 1-1 to set whether the system has a boiler.

Dip SW 1-1	Setting
OFF	WITHOUT boiler
ON	WITH boiler

When Dip SW 1-1 is OFF, back-up operation of boiler is not available.

Set Dip SW 2-6 to set whether the system has a mixing tank.

Dip SW 2-6	Setting
OFF	WITHOUT mixing tank
ON	WITH mixing tank

When Dip SW 2-6 is OFF, back-up operation of boiler is not available.

When Dip SW 2-7 is OFF, 2-zone temperature control is not available.

Set Dip SW 2-7 to set activate or deactivate 2-zone temperature control.

Dip SW 2-7	Setting
OFF	Inactive
ON	Active

When Dip SW 2-7 is OFF, 2-zone temperature control is not available.

Set Dip SW 4-1 to set activate or deactivate multiple units control.

Dip SW 4-1	Setting
OFF	Inactive
ON	Active

When Dip SW 4-1 is OFF, 2-zone temperature control is not available.

Set Dip SW 4-2 to set master or slave of multiple units control.

Dip SW 4-2	Setting
OFF	Slave
ON	Master

When multiple units control is not available, setting of Dip SW 4-2 is not necessary.

5. Dip Switch setting

<Summary of Function setting>

Dip SW 1-3 (DHW tank)	Dip SW 1-4 (Immersion heater)	Dip SW 1-5 (Booster heater)	Dip SW 1-6 (BH function)	System diagram
ON (WITH DHW tank)	OFF (WITHOUT immersion heater)	ON (WITH booster heater)	ON (For heating and DHW)	
ON (WITH DHW tank)	ON (WITH immersion heater)	ON (WITH booster heater)	ON (For heating and DHW)	
ON (WITH DHW tank)	OFF (WITHOUT immersion heater)	ON (WITH booster heater)	OFF (For heating only)	
ON (WITH DHW tank)	OFF (WITHOUT immersion heater)	OFF (WITHOUT booster heater)	—	
ON (WITH DHW tank)	ON (WITH immersion heater)	ON (WITH booster heater)	OFF (For heating only)	
ON (WITH DHW tank)	ON (WITH immersion heater)	OFF (WITHOUT booster heater)	—	
OFF (WITHOUT DHW tank)	OFF (WITHOUT immersion heater)	ON (WITH booster heater)	OFF	
OFF (WITHOUT DHW tank)	OFF (WITHOUT immersion heater)	OFF (WITHOUT booster heater)	—	

* The use of two 2-way valves can perform same function as a 3-way valve.

5. Dip Switch setting

5.4 Operation setting

Set Dip SW 1-8 to set whether the system has a wireless remote controller.

Dip SW 1-8	Setting
OFF	WITHOUT wireless remote controller
ON	WITH wireless remote controller

Set Dip SW 2-1 to set the room thermostat 1 input (IN1) logic.

Dip SW 2-1	Setting
OFF	Operation stop at thermostat short
ON	Operation stop at thermostat open

Set Dip SW 2-2 to set the flow switch 1 input (IN2) logic.

Dip SW 2-2	Setting
OFF	Failure detection at short
ON	Failure detection at open

Set Dip SW 2-3 to set the restriction on the capacity of booster heater.

Dip SW 2-3	Setting
OFF	Inactive
ON	Active

When Dip SW 2-3 is ON, booster heater 2 and 2+ operation is not available. (Only booster heater 1 is available)

Notes: ① When installing one booster heater, use OUT6 (Booster Heater 1) and switch SW2-3 to ON.

② When installing two booster heaters, use OUT6 (Booster Heater 1) and OUT7 (Booster heater 2). In such cases, use OUT7 (Booster heater 2) to connect the one with higher capacity. Or, make the sum of the capacities of OUT7 (Booster heater 2) and OUT8 (Booster 2+) greater than the capacity of OUT6 (Booster 1).

Reference: Summary of Booster heater control

The booster heater is controlled in the following three steps.

		Booster heater 1 (OUT6)	Booster heater 2 (OUT7)	Booster heater 2+ (OUT8)	
OFF		OFF	OFF	OFF	} Controlled to this extent when SW2-3 is ON.
ON	STEP 1	ON	OFF	OFF	
	STEP 2	OFF	ON	ON	
	STEP 3	ON	ON	ON	

Output synchronised with Booster heater 2

Set Dip SW 2-4 to set activate or deactivate cooling mode.

Dip SW 2-4	Setting
OFF	Inactive
ON	Active

When Dip SW 2-4 is OFF, cooling mode is not available.

Set Dip SW 2-5 to set the automatic switch to backup heater only operation. (When outdoor unit stops by error.)

Dip SW 2-5	Setting
OFF	Inactive
ON	Active

Set Dip SW 3-1 to set the room thermostat 2 input (IN6) logic.

Dip SW 3-1	Setting
OFF	Operation stop at thermostat short
ON	Operation stop at thermostat open

Set Dip SW 3-2 to set the flow switch 2 input (IN3) logic.

Dip SW 3-2	Setting
OFF	Operation stop at thermostat short
ON	Operation stop at thermostat open

Set Dip SW 3-3 to set the flow switch 3 input (IN7) logic.

Dip SW 3-3	Setting
OFF	Operation stop at thermostat short
ON	Operation stop at thermostat open

Set Dip SW3-4 whether to make cooling operation in Zone 2 available.

Dip SW 3-4	Setting
OFF	Not in use
ON	In use

When Dip SW3-4 is set to OFF, cooling operation in Zone 2 is not available.

Set Dip SW 3-5 to set activate or deactivate heating mode.

Dip SW 3-5	Setting
OFF	Inactive
ON	Active

When the connected outdoor unit is not of PUAZ-FRP model, heating mode is always active regardless of Dip SW3-5 setting.

5. Dip Switch setting

5.5 Emergency mode (Heater only operation)

The emergency mode is available when a failure on the outdoor unit of the heat pump or a communication error occurs.

This mode uses booster heater or immersion heater as a heat source and automatically controls between the DHW mode and the heating mode. When the system is not incorporated with heater, the emergency mode is not available.

Before starting the emergency mode, turn off the outdoor unit and FTC4 (Master), and then turn Dip SW 4-5 to ON. Then, turn on FTC4 (Master) to start the emergency mode. FTC4 (Master) can be power-supplied by the outdoor unit or directly by power source.

If emergency mode is no longer required, please turn off both outdoor and indoor unit power supply before returning Dip SW4-5 to OFF position.

5.6 Emergency mode (Boiler operation)

The emergency mode is available when a failure on the outdoor unit of the heat pump or a communication error occurs.

This mode uses boiler as a heat source and automatically controls the heating mode. When the system is not incorporated with boiler, the emergency mode is not available.

Before starting the emergency mode, turn off the outdoor unit and FTC4 (Master), and then turn Dip SW 4-6 to ON. Then, turn on FTC4 (Master) to start the emergency mode. FTC4 (Master) can be power-supplied by the outdoor unit or directly by power source.

If emergency mode is no longer required, please turn off both outdoor and indoor unit power supply before returning Dip SW4-6 to OFF position.

6. Before test run

6.1. Check

After completing installation and the wiring and piping of the local application and outdoor units, check for refrigerant leakage, looseness in the power supply or control wiring, wrong polarity, and power cable is securely connected.

Use a 500-volt megohmmeter to check that the resistance between the power supply terminals and ground is at least 1.0MΩ.

Warning:

Do not use the system if the insulation resistance is less than 1.0MΩ.

Caution:

Do not carry out this test on the control wiring (low voltage circuit) terminals.

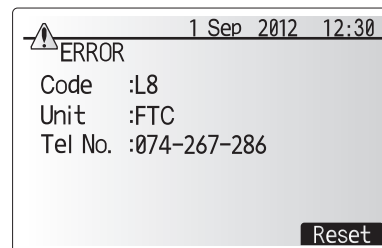

6.2. Self-check

When an error occurs when power is applied or during operation

- Indication of error details

The code, unit, address, and telephone number are displayed.

The telephone number is displayed if registered.

- Resetting the error

Press the F4 (RESET) button, and the F3 (Yes) button to reset the current error.

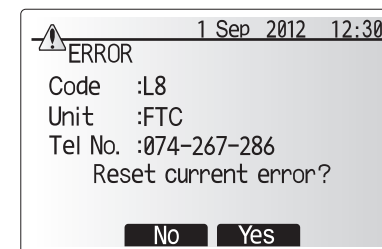

Code	Error	Action
L3	Circulation water temperature overheat protection	Flow rate may be reduced check for; <ul style="list-style-type: none"> • Water leakage • Strainer blockage • Water circulation pump function (Error code may display during filling of primary circuit, complete filling and reset error code.)
L4	DHW tank water temperature overheat protection	Check the immersion heater and it's contactor.
L5	Indoor unit temperature thermistor (THW1, THW2, THW5, THW6, THW7, THW8, THW9) failure	Check resistance across the thermistor.
L6	Circulation water freeze protection	See Action for L3.
L8	Heating operation error	Re-attach any thermistors that have become dislodged.
L9	Low primary circuit flow rate detected by flow switch (flow switches 1, 2, 3)	See Action for L3. If the flow switch itself does not work, replace it. Caution: The pump valves may be hot, please take care.
LC	Boiler circulation water temperature overheat protection	Check if the setting temperature of the Boiler for heating exceeds the restriction. (See the manual of the thermistors "PAC-TH011HT-E") Flow rate of the heating circuit from the boiler may be reduced. Check for <ul style="list-style-type: none"> • water leakage, • strainer blockage • water circulation pump function.
LD	Boiler temperature thermistor (THWB1, THWB2) failure	Check resistance across the thermistor.
LE	Boiler operation error	See Action for L8. Check the status of the boiler.
LH	Boiler circulation water freeze protection	Flow rate of the heating circuit from the boiler may be reduced. Check for <ul style="list-style-type: none"> • water leakage • strainer blockage • water circulation pump function.
LL	Setting errors of Dip switches on FTC4 control board	For boiler operation, check that Dip SW1-1 is set to ON (With Boiler) and Dip SW2-6 is set to ON (With Mixing Tank). For 2-zone temperature control, check Dip SW2-7 is set to ON (2-zone) and Dip SW2-6 is set to ON (With Mixing Tank). For multiple outdoor units control system, check that Dip SW1-3 is set to ON on the slave unit that runs DHW operation.
J0	Communication failure between FTC4 and wireless receiver	Check connection cable for damage or lose connections.
P1	Thermistor (Room temp.) (TH1) failure	Check resistance across the thermistor.
P2	Thermistor (Ref. liquid temp.) (TH2) failure	Check resistance across the thermistor.
P6	Anti-freeze protection of plate heat exchanger	See Action for L3. Check for correct amount of refrigerant.
J1 - J8	Communication failure between wireless receiver and wireless remote controller	Check wireless remote controller's battery is not flat. Check the pairing between wireless receiver to wireless remote controller. Test the wireless communication. (See the manual of wireless system)
J9	Communication failure between main controller and FTC4 (Slave)	Check connection cable for damage or loose connections.
E0 - E5	Communication failure between main controller and FTC4	Check connection cable for damage or loose connections.
E6 - EF	Communication failure between FTC4 and outdoor unit	Check that the outdoor unit has not been turned off. Check connection cable for damage or loose connections. Refer to outdoor unit service manual.
E9	Outdoor unit receives no signal from indoor unit.	Check both units are switched on. Check connection cable for damage or loose connections. Refer to outdoor unit service manual.
U*, F*	Outdoor unit failure	Refer to outdoor unit service manual.

Note: To cancel error codes please switch system off (Press button E, on Main Controller, for 3 secs).

For description of each LED (LED1 to 3) provided on the FTC4, refer to the following table.

LED 1 (Power for microcomputer)	Indicates whether control power is supplied. Make sure that this LED is always lit.
LED 2 (Power for main controller)	Indicates whether power is supplied to the main controller. This LED lights only in the case of the FTC4 (Master) unit which is connected to the outdoor unit refrigerant address "0".
LED 3 (Communication between FTC4 and outdoor unit)	Indicates state of communication between the FTC4 and outdoor unit. Make sure that this LED is always blinking.

7. Main controller operation

Note (Marking for WEEE)



This symbol mark is for EU countries only.

This symbol mark is according to the directive 2002/96/EC Article 10 Information for users and Annex IV.

Your MITSUBISHI ELECTRIC product is designed and manufactured with high quality materials and components which can be recycled and re-used.

This symbol means that electrical and electronic equipment, at their end-of-life, should be disposed of separately from your household waste.

Please, dispose of this equipment at your local community waste collection/recycling centre.

In the European Union there are separate collection systems for used electrical and electronic product.

Please, help us to conserve the environment we live in!

7.1. Safety precautions

FOR USER

- ▶ Before installing the unit, make sure you read all the “Safety Precautions”.
- ▶ The “Safety Precautions” provide very important points regarding safety. Make sure you follow them.
- ▶ Please report to or take consent by the supply authority before connection to the system.

Symbols used in the text

Warning:

Describes precautions that should be observed to prevent danger of injury or death to the user.

Caution:

Describes precautions that should be observed to prevent damage to the unit.

Symbols used in the illustrations

: Indicates a part which must be grounded.

Warning:

- For appliances not accessible to the general public.
- The unit must not be installed by the user. Ask the dealer or an authorized company to install the unit. If the unit is installed improperly, water leakage, electric shock or fire may result.
- Do not stand on, or place any items on the unit.
- Do not splash water over the unit and do not touch the unit with wet hands. An electric shock may result.
- Do not spray combustible gas close to the unit. Fire may result.
- Do not place a gas heater or any other open-flame appliance where it will be exposed to the air discharged from the unit. Incomplete combustion may result.
- Do not remove the front panel or the fan guard from the outdoor unit when it is running.
- When you notice exceptionally abnormal noise or vibration, stop operation, turn off the power switch, and contact your dealer.

- Never insert fingers, sticks etc. into the intakes or outlets.
- If you detect odd smells, stop using the unit, turn off the power switch and consult your dealer. Otherwise, a breakdown, electric shock or fire may result.
- If the supply cable is damaged, it must be replaced by the manufacturer, its service agent or similarly qualified persons in order to avoid a hazard.
- This appliance is not intended for use by persons (including children) with reduced physical, sensory or mental capabilities, or lack of experience and knowledge, unless they have been given supervision or instruction concerning use of the appliance by a person responsible for their safety.
- Children should be supervised to ensure that they do not play with the appliance.
- If the refrigeration gas blows out or leaks, stop the operation of the air conditioner, thoroughly ventilate the room, and contact your dealer.
- Do not install in location that is hot or humid for long periods of time.

Caution:

- Do not use any sharp object to push the buttons, as this may damage the main controller.
- Never block or cover the indoor or outdoor unit's intakes or outlets.

Disposing of the unit

When you need to dispose of the unit, consult your dealer.

7. Main controller operation

7.2 Main Controller

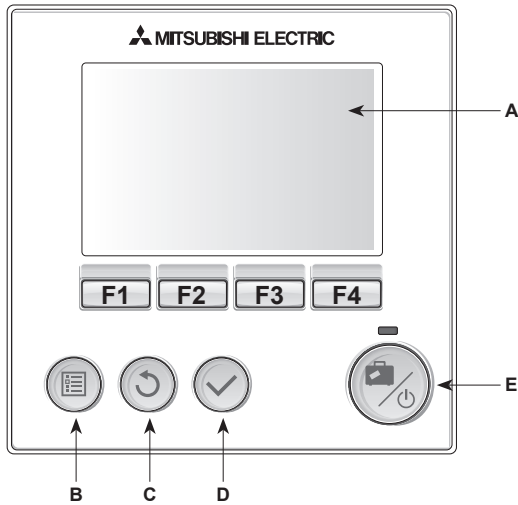

<Main controller parts>

Letter	Name	Function
A	Screen	Screen in which all information is displayed
B	Menu	Access to system settings for initial set up and modifications.
C	Back	Return to previous menu.
D	Confirm	Used to select or save. (Enter key)
E	Power/Holiday	If system is switched off pressing once will turn system on. Pressing again when system is switched on will enable Holiday Mode. Holding the button down for 3 secs will turn the system off. (*1)
F1-4	Function keys	Used to scroll through menu and adjust settings. Function is determined by the menu screen visible on screen A.

*1

When the system is switched off or the power supply is disconnected, the water circuit protection functions (e.g. freeze stat. function) will NOT operate. Please beware that without these safety functions enabled the water circuit may potentially become exposed to damage.

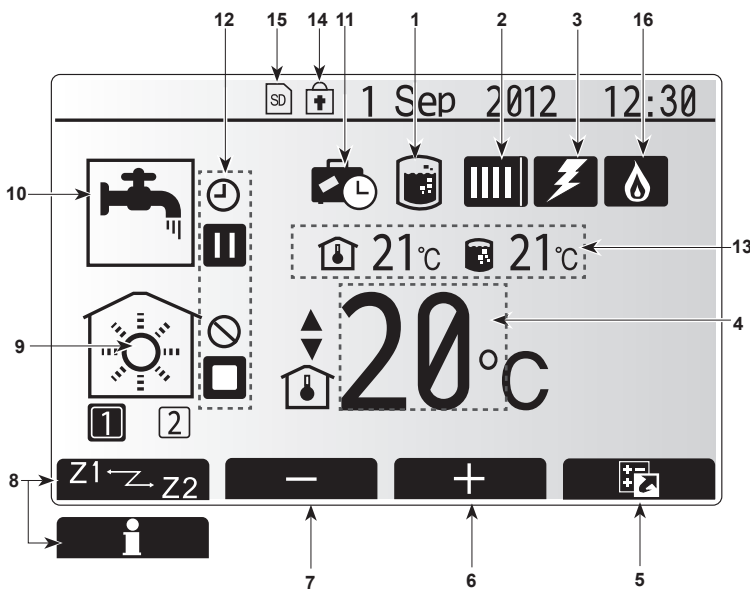

<Main screen icons>

	Icon	Description
1	Legionella prevention	When this icon is displayed 'Legionella prevention mode' is active.
2	Heat pump	'Heat pump' is running.
		Defrosting.
		Emergency heating.
3	Electric heater	When this icon is displayed the 'Electric heaters' (booster or immersion heater) are in use.
4	Target temperature	Target flow temperature
		Target room temperature
		Compensation curve
5	OPTION	Pressing the function button below this icon will display the quick view menu.
6	+	Increase desired temperature.
7	-	Decrease desired temperature.
8	Z1 Z2	Pressing the function button below this icon switches between Zone1 and Zone2.
	Information	Pressing the function button below this icon displays the information screen.
9	Space heating (cooling) mode	Heating mode Zone1 or Zone2
		Cooling mode
10	DHW mode	Normal or ECO mode
11	Holiday mode	When this icon is displayed 'Holiday mode' activated.
12	Timer	Timer
		Prohibited
		Stand-by
		Stop
13	Current temperature	Current room temperature
		Current water temperature of DHW tank
14	Lock	The Menu button is locked.
15	SD	SD memory card is inserted. Normal operation.
		SD memory card is inserted. Abnormal operation.
16	Boiler	When this icon is displayed, 'Boiler' is in use.

7. Main controller operation

<Main Controller Menu Tree>

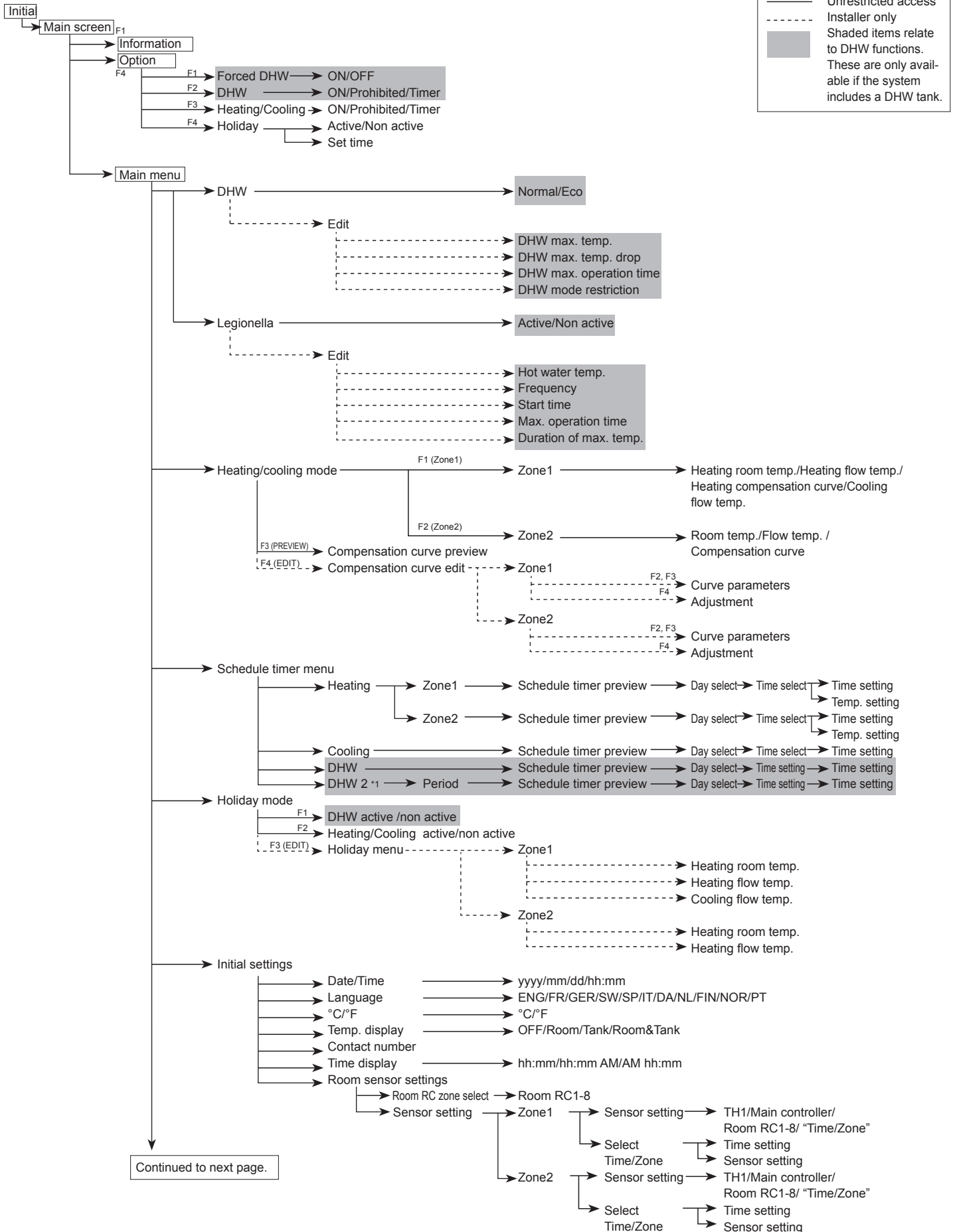

Continued to next page.

*1 When a PUHZ-FRP outdoor unit is connected.

7. Main controller operation

<Main Controller Menu Tree>

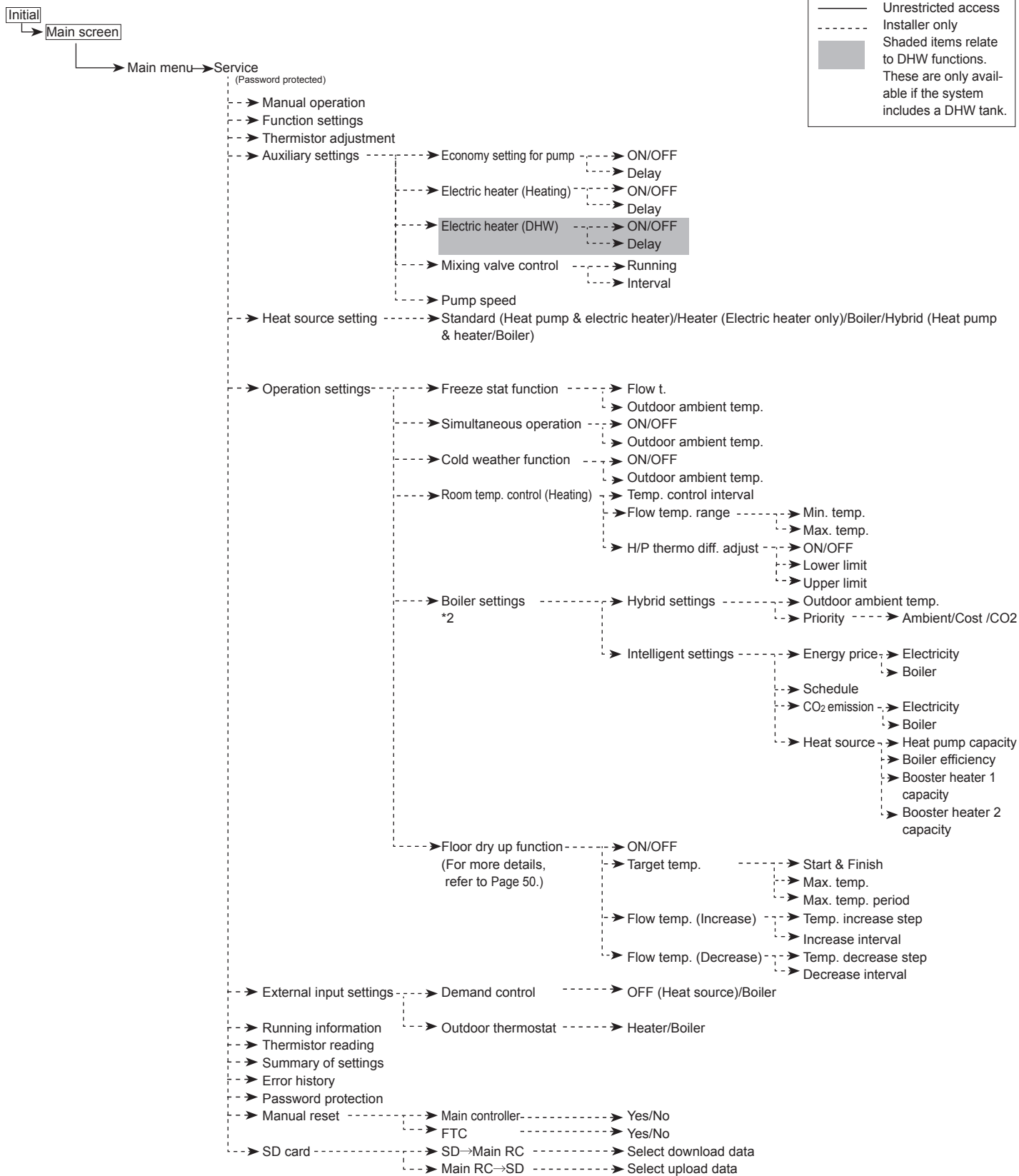

————— Unrestricted access
 - - - - - Installer only
 ■ Shaded items relate to DHW functions. These are only available if the system includes a DHW tank.

*2 For more details, refer to the installation manual of PAC-TH011HT-E.

Continued from the previous page.

7. Main controller operation

■ Setting the Main Controller

After the power has been connected to the outdoor unit and hydrobox (See section 4.1) the initial system settings can be entered via the main controller.

1. Check all breakers and other safety devices are correctly installed and turn on power to the system.
2. When the main controller switched on for the first time, the screen automatically goes to Initial settings menu, Language setting screen and Date/Time setting screen in order.
3. Main controller will automatically start up. Wait approximately 6 mins whilst the control menus load.
4. When the controller is ready a blank screen with a line running across the top will be displayed.
5. Press button E (Power) (refer to page 33) to turn on the system. Before turning on the system, perform initial settings as instructed below.



■ Main Settings Menu

The main settings menu can be accessed by pressing the MENU button. To reduce the risk of untrained end users altering the settings accidentally there are two access levels to the main settings; and the service section menu is password protected.

User Level – Short press

If the MENU button is pressed once for a short time the main settings will be displayed but without the edit function. This will enable the user to view current settings but **NOT** change the parameters.

Installer Level – Long press

If the MENU button is pressed down for 3 secs the main settings will be displayed with all functionality available.

The following items can be viewed and/or edited (dependent on access level).

- Domestic Hot water (DHW)
- Heating/Cooling
- Schedule timer
- Holiday mode
- Initial settings
- Service (Password protected)

Use the F2 and F3 buttons to move between the icons. The highlighted icon will appear as a larger version in the centre of the screen. Press CONFIRM to select and edit the highlighted mode.

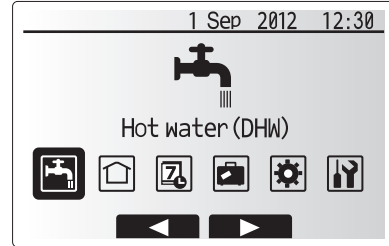

Icon	Description
	Hot water (DHW)
	Heating/Cooling
	Schedule timer
	Holiday mode
	Initial settings
	Service

■ Initial Settings

From the Initial settings menu the installer can set the following.

- Date/Time
- Language
- °C/°F
- Temp. display
- Contact number
- Time display
- Room sensor settings

1. Use buttons F1 and F2 to move scroll through the menu list. When the title is highlighted press CONFIRM to edit.
2. Use function buttons appropriate to edit each setting then press CONFIRM to save the setting.

<Room sensor settings>

For room sensor settings it is important to choose the correct room sensor depending on the heating mode the system will operate in.

1. From the Initial settings menu select Room sensor settings.

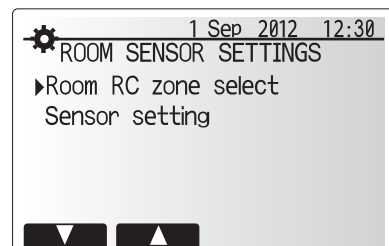
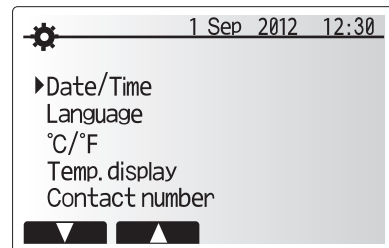

7. Main controller operation

2. When 2-zone temperature control is active or wireless remote controllers are available, from Room RC zone select screen, select zone no. to assign to each remote controller.

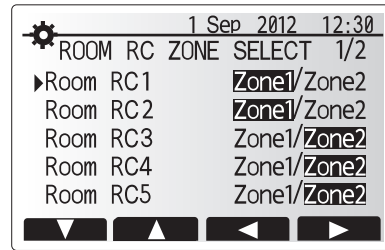

3. From Sensor setting screen, select a room sensor to be used for monitoring the room temperature from Zone1 and Zone2 separately.

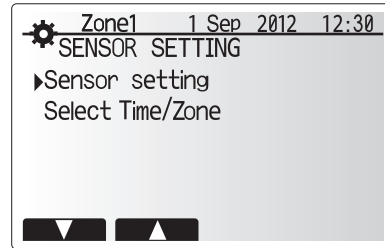

Control option (pages 33 and 34)	Corresponding initial settings room sensor	
	Zone1	Zone2
A	Room RC1-8 (one each for Zone1 and Zone2)	*
B	TH1	*
C	Main controller	*
D	*	*

* Not specified (if a field-supplied room thermostat is used)

Room RC1-8 (one each for Zone1 and Zone2) (if a wireless remote controller is used as a room thermostat)

4. From Sensor setting screen, select Time/Zone to make it possible to use different room sensors according to the time schedule set in the Select Time/Zone menu. The room sensors can be switched up to 4 times within 24 hours .

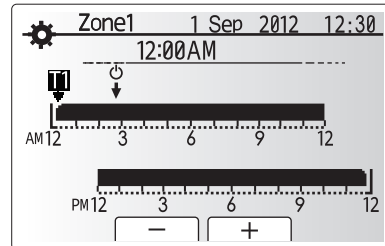
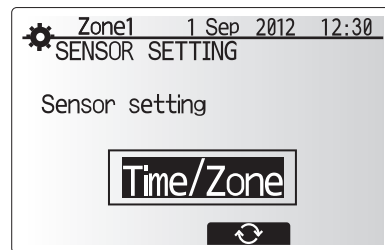

Time/Zone schedule setting screen

■ Domestic Hot Water (DHW)/Legionella Prevention

The domestic hot water and legionella prevention menus control the operation of DHW tank heat ups.

<DHW mode settings>

1. Highlight the hot water icon and press CONFIRM.
2. Use button F1 to switch between Normal and ECO heating modes.
3. To edit the mode press F2 to display the HOT WATER (DHW) SETTING menu.
4. Use F2 and F3 keys to scroll through the menu selecting each component in turn by pressing CONFIRM. See the table below for description of each setting.
5. Enter the desired number using the function keys and press CONFIRM.

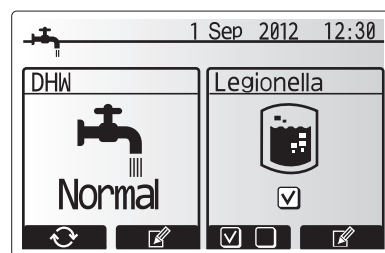

Menu subtitle	Function	Range	Unit	Default value
DHW max. temp	Desired temperature of stored hot water	40 - 60	°C	50
DHW max. temperature drop	Difference in temperature between DHW max. temp and the temperature at which DHW mode restarts	5 - 30	°C	10
DHW max. operation time	Max time allowed for stored water heating DHW mode	30 - 120	min	60
DHW mode restriction	The time period after DHW mode when space heating has priority over DHW mode temporarily preventing further stored water heating (Only when DHW max. operation time has passed.)	30 - 120	min	30

7. Main controller operation

Explanation of DHW operation

- When the DHW tank temperature drops from "DHW max. temp" by more than the "DHW max. temperature drop" (set by installer), DHW mode operates and the flow from the primary heating/cooling circuit is diverted to heat the water in the DHW tank.
- When the temperature of the stored water reaches the 'DHW max. temp.' set by the installer or if the 'DHW max. operation time' set by the installer is exceeded DHW mode ceases to operate.
- Whilst DHW mode is in operation primary hot water is not directed to the space heating/cooling circuit.
- Directly after DHW max. operation time 'DHW mode restriction' will routinely operate. The duration of this feature is set by the installer and during its operation DHW mode can not (normally) be reactivated, allowing time for the system to deliver primary hot water to the space heating/cooling if required. However, if at this time there is no current demand for space heating/cooling, the system will automatically resume DHW mode. This will continue until it receives a demand for space heating/cooling.
- After the 'DHW mode restriction' operation the DHW mode can operate again and DHW tank heating will continue according to system demand.

<Eco mode>

DHW mode can run in either 'Normal' or 'Eco' mode. Normal mode will heat the water in the DHW tank more quickly using the full power of the heat pump. Eco mode takes a little longer to heat the water in the DHW tank but the energy used is reduced. This is because heat pump operation is restricted using signals from the FTC4 based on measured DHW tank temperature.

Note: The actual energy saved in Eco mode will vary according to outdoor ambient temperature.

Return to the DHW/legionella prevention menu.

Legionella Prevention Mode settings (LP mode)

1. Use button F3 to choose legionella mode active YES/NO.
2. Use button F4 to edit the legionella function.
3. Use F1 and F2 keys to scroll through the menu selecting each subtitle in turn by pressing CONFIRM. See the table below for description of each setting.
4. Enter the desired number using the function keys and press CONFIRM.

During Legionella Prevention Mode the temperature of the stored water is increased above 60°C to inhibit legionella bacterium growth. It is strongly recommended that this is done at regular intervals. Please check local regulations for the recommended frequency of heat ups.

Note: When failures occur on the hydrobox, the LP mode may not function normally.

Menu subtitle	Function	Range	Unit	Default value
Hot water temp.	Desired temp of stored hot water	60–70	°C	65
Frequency	Time between LP mode DHW tank heat ups	1–30	day	15
Start time	Time when LP mode will begin	0:00–23:00	-	03:00
Max. operation time	Maximum time allowed for LP mode DHW tank heat	1–5	hour	3
Duration of max. temp.	The time period after LP mode max. water temp has been reached	1–120	min	30

Explanation of Legionella Prevention Mode operation

- At the time entered by the installer 'Start time' flow of useful heat from the system is diverted to heat the water in the DHW tank.
- When the temperature of the stored water exceeds the 'Hot Water temp.' set by the installer (above 65°C) primary circuit water is no longer diverted to heat the DHW tank.
- Whilst LP mode is in operation hot water is not directed to the space heating /cooling circuit.
- Directly after LP mode operation 'Duration of max. temp' will operate. The duration of this feature is set by the installer and during its operation stored water temperature will be monitored.
- If stored water temperature should drop to LP restart temp, LP mode will restart and primary water flow from the heat source(s) will be directed to the DHW tank to boost the temperature. Once the set time for Duration of Max. temp has passed LP mode will not recur for the set interval (set by installer).
- It is the responsibility of the installer to ensure the settings for legionella prevention are compliant with local and national guidelines.

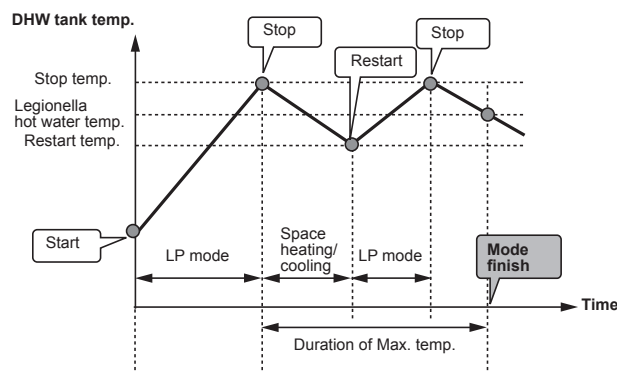
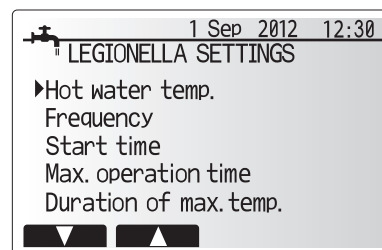
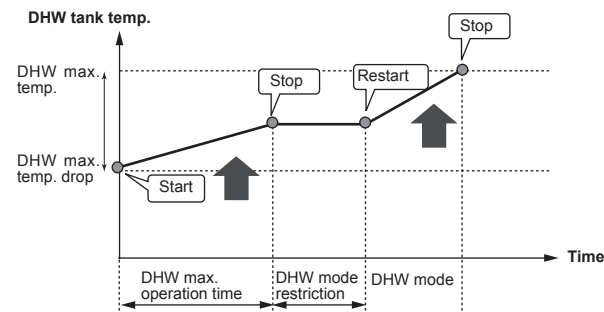
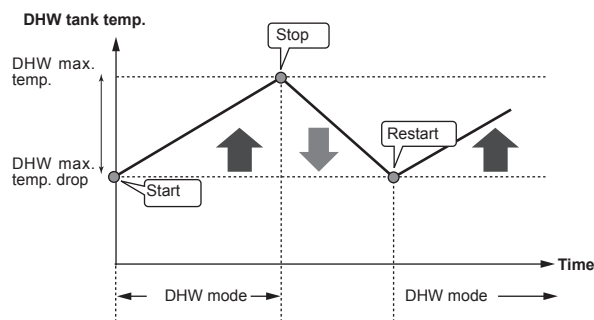

(LP mode: Legionella Prevention mode)

Please note that LP mode uses the assistance of electric heaters (if present) to supplement the energy input of the heat pump. Heating water for long periods of time is not efficient and will increase running costs. The installer should give careful consideration to the necessity of legionella prevention treatment whilst not wasting energy by heating the stored water for excessive time periods. The end user should understand the importance of this feature.
ALWAYS COMPLY WITH LOCAL AND NATIONAL GUIDANCE FOR YOUR COUNTRY REGARDING LEGIONELLA PREVENTION.

7. Main controller operation

Forced DHW

The forced DHW function is used to force the system to operate in DHW mode. In normal operation the water in the DHW tank will be heated either to the set temperature or for the maximum DHW time, whichever occurs first. However should there be a high demand for hot water 'Forced DHW' function can be used to prevent the system from routinely switching to space heating/cooling and continue to provide DHW tank heating.

Forced DHW operation is activated by pressing button F1 and Back button in the 'Option Screen'. After DHW operation finishes, the system will automatically return to normal operation. To cancel forced DHW operation hold down button F1 in the 'Option Screen'.

■ Heating/Cooling

The heating and cooling menus deal with space heating and cooling typically using either a radiator or underfloor system depending on the installation.

From the main settings menu

1. Use F2 and F3 buttons to highlight heating/cooling icon then press CONFIRM.
2. The heating and cooling menu will be displayed.
3. To select the sub-menus press the function button below the icon required. E.g. for mode change of Zone1 press F1

Heating/Cooling

1. Under this sub-menu the mode of heating or cooling is selected.
2. Choose between

- Heating flow temperature (🔥)
- Heating room temperature (🏠)
- Heating compensation curve (📈)
- Cooling flow temperature (❄️)

Heating room temperature cannot be selected both in Zone1 and Zone2.

When Cooling flow temp. is selected in Zone1, Cooling flow temp is automatically selected in Zone2. Zone1 and Zone2 are controlled at the same set temperature. If using an underfloor system in Cooling mode, do not set the flow temperature too low to avoid formation of condensation.

3. To choose between the different modes for heating and cooling, highlight the mode preferred and press select.

If compensation curve mode was selected as the heating mode please read the following instructions.

Explanation of compensation curve

During late spring and summer usually the demand for space heating is reduced. To prevent the heat pump from producing excessive flow temperatures for the primary circuit the compensation curve mode can be used to maximise efficiency and reduce running costs.

The compensation curve is used to restrict the flow temperature of the primary space heating circuit dependent on the outdoor ambient temperature. The FTC4 uses information from both an outdoor ambient temperature sensor and a temperature sensor on the primary circuit supply to ensure the heat pump is not producing excessive flow temperatures if the weather conditions do not require it.

<Compensation curve setting>

*This setting cannot be performed in cooling mode.

1. From the heating menu select edit using the F3 function button.
2. The compensation curve setting screen will be displayed.
3. In 2-zone heating operation, press F1 to switch between Zone1 and Zone2.
4. Press F2 to alter the Hi parameter (when flow temp is maximum and outdoor ambient temp is minimum).
5. Press F3 to alter the Lo parameter (when flow temp is minimum and outdoor ambient temp is maximum).
6. Press F4 to add an extra point (adjust).

Pressing F2-4 will cause the relevant edit screen to be displayed. Editing Lo and Hi parameters is done in the same way; please see the following for more detailed explanation of parameter editing.

In the parameter (Lo/Hi) edit screen the flow temperature and outdoor ambient temperature for the compensation curve graph can be set and altered for the 2 extremes of Hi and Lo.

1. Press F1 and F2 to change the flow temperature (y-axis of compensation curve).
2. Pressing F1 will raise the desired flow temperature for the set outdoor ambient temperature.
3. Pressing F2 will lower the desired flow temperature for the set outdoor ambient temperature.
4. Press F3 and F4 to change the outdoor ambient temperature (x-axis of compensation curve).
5. Pressing F3 will lower the outdoor ambient temperature for the set flow temperature.
6. Pressing F4 will raise the outdoor ambient temperature for the set flow temperature.

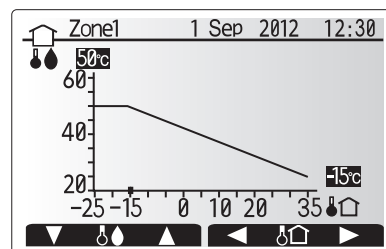
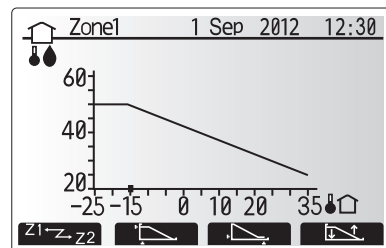
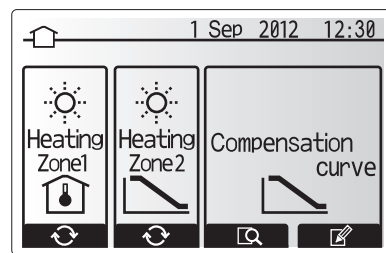

7. Main controller operation

■ Holiday mode

Holiday mode can be activated in 2 ways. Both methods will result in the Holiday Mode activation screen being shown.

Option 1.

From the main menu screen button E should be pressed. Be careful not to hold down button E for too long as this will turn off the controller and system.

Option 2.

From the main menu screen press button F4. The current settings screen will be displayed. Press button F4 again to access the holiday mode activation screen.

Once the holiday mode activation screen is displayed you can activate/deactivate and select the duration that you would like holiday mode to run for.

- Press button F1 to activate or deactivate holiday mode.
- Use buttons F2, F3 and F4 to input the date which you would like holiday mode to activate or deactivate for space heating/cooling.

<Editing holiday mode>

To change the Holiday mode settings e.g. the flow temp, you must access the holiday mode menu from the main settings menu.

1. From main menu screen press button B.
2. Use buttons F2 and F3 to scroll through menu until Holiday Mode is highlighted.
3. Press CONFIRM button.
4. The holiday mode status screen is displayed.
5. To change the flow temperature or room temperatures on heating mode press button F3.
6. A list of variables will be displayed. Choose the one you wish to modify using buttons F1/F2 then press CONFIRM.
7. Adjust the temperature using buttons F3 and F2 and press CONFIRM button to save changes.

■ Schedule timer

The schedule timer mode allows daily and weekly space heating/cooling and DHW patterns to be entered.

1. From the main settings menu use F2 and F3 to highlight the schedule timer icon then press CONFIRM.
2. The schedule timer sub menu will be displayed. The icons show the following modes;
 - Heating
 - Cooling
 - Hot Water (DHW)
3. Use F2 and F3 buttons to move between mode icons then press CONFIRM to be shown the preview screen for each mode.

The preview screen allows you to view the current settings. In 2-zone heating operation, press F1 to switch between Zone1 and Zone2. Days of the week are displayed across the top of the screen. Where day appears underlined the settings are the same for all those days.

Hours of the day and night are represented as a bar across the main part of the screen. Where the bar is solid black, space heating/DHW (whichever is selected) is allowed.

When a PUAZ-FRP outdoor unit is connected, DHW schedule timer setting can be set for two periods into which a year is divided. In this menu screen, the duration of Period 2 can be entered. The rest of the set duration comes set as Period 1.

1. From the main settings menu use F2 and F3 to highlight the schedule timer icon then press CONFIRM.
2. The schedule timer sub menu will be displayed. The icons show the following modes;
 - Heating
 - Hot Water (DHW)
 - Hot Water (DHW) 2
3. Use F2 and F3 buttons to move between mode icons to select the Hot Water (DHW) 2 icon.
4. Use F1 to F4 buttons to select start and end months that apply to Period 2.
5. Press CONFIRM to be shown the preview screen for each mode.

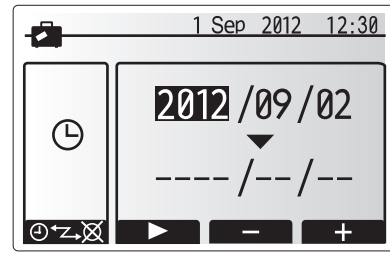

Holiday Mode activation screen

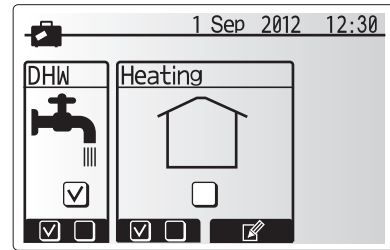

Holiday Mode status screen

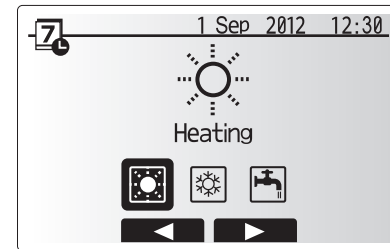

Mode select screen

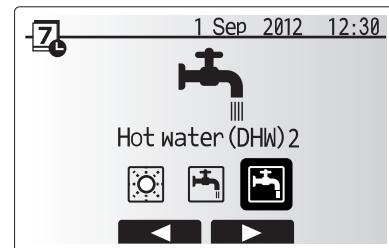

Mode select screen when PUAZ-FRP connected

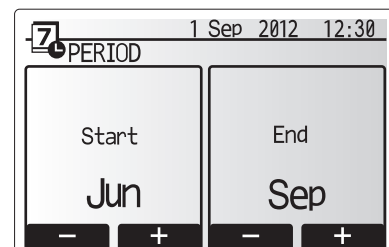

Period setting screen when PUAZ-FRP connected

7. Main controller operation

<Setting the schedule timer>

1. In the preview menu screen press F4 button.
* In the case of 2-zone system, press F1 button to switch between Zone1 and Zone2.

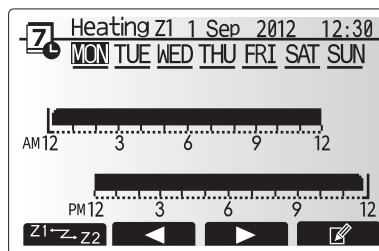

Preview screen

2. First select the days of the week you wish to schedule.
3. Press F2/F3 buttons to move between days and F1 to check or uncheck the box.
4. When you have selected the days press CONFIRM.

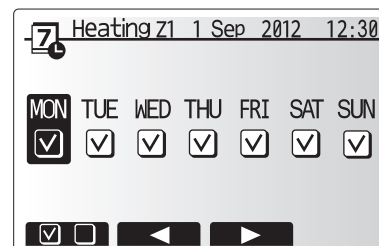

Day of week select screen

5. The time bar edit screen will be displayed.
6. Use buttons F2/F3 to move to the point at which you do not want the selected mode to be active press CONFIRM to start.
7. Use F3 button to set the required time of inactivity then press CONFIRM.
8. You can add up to 4 periods of inactivity within a 24 hour interval.

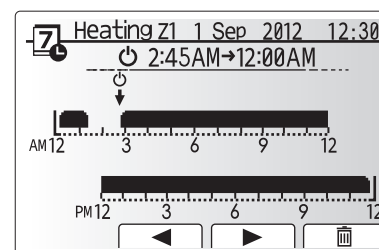

Time of period setting screen 1

9. Press F4 to save settings.

When scheduling heating, button F1 changes the scheduled variable between time and temperature. This enables a lower temperature to be set for a number of hours e.g. a lower temperature may be required at night when the occupants are sleeping.

Note:

- The schedule timer for space heating/cooling and DHW are set in the same way. However for Cooling and DHW only time can be used as scheduling variable.
- A small rubbish bin character is also displayed choosing this icon will delete the last unsaved action.
- It is necessary to use the SAVE function F4 button to save settings. CONFIRM does NOT act as SAVE for this menu.

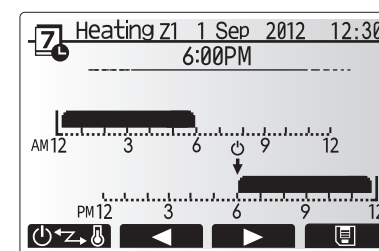

Time of period setting screen 2

7. Main controller operation

■ Service Menu

The service menu provides functions for use by installer or service engineer. It is NOT intended the home owner alters settings within this menu. It is for this reason password protection is required to prevent unauthorised access to the service settings.

1. From the main setting menu use F2 and F3 to highlight the service icon then press CONFIRM.
2. You will be prompted to enter a password. **THE FACTORY DEFAULT PASSWORD IS "0000"**.
3. Press CONFIRM.
(It takes approx. 30 secs to load the service menu.)

The service menu is navigated using the F1 and F2 buttons to scroll through the functions. The menu is split across two screens and is comprised of the following functions;

1. Manual operation
2. Function settings
3. Thermistor adjustment
4. Auxiliary settings
5. Heat source setting
6. Operation settings
7. External input settings
8. Running information
9. Thermistor reading
10. Summary of settings
11. Error history
12. Password protection
13. Manual reset
14. SD card

In this Installation Manual, instructions will be given only for the following functions;

1. Manual operation
2. Auxiliary settings
3. Heat source setting
4. Operation settings
5. External input settings
6. Password protection
7. Manual reset
8. SD card

Information on the other functions can be found by consulting the service manual.

Note: Many functions can not be set whilst the indoor unit is running. The installer should turn OFF the unit before trying to set these functions. If the installer attempts to change the settings whilst the unit is running the main controller will display a reminder message prompting the installer to stop operation before continuing. By selecting "Yes" the unit will cease operation.

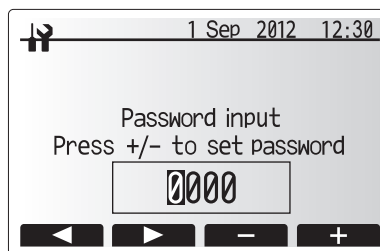

Screen 1 of service menu

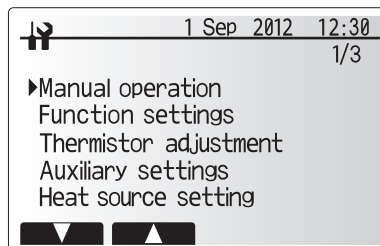

Screen 2 of service menu

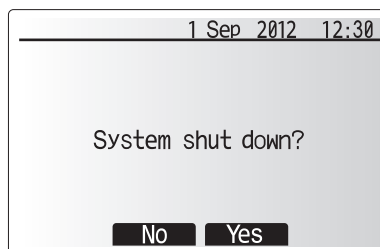

System off prompt screen

7. Main controller operation

Manual operation

During the filling of the system the water circulation pump and 3-way valve can be manually overridden using manual operation mode.

When manual operation is selected a small timer icon appears in the screen. The function selected will only remain in manual operation for a maximum of 2 hours. This is to prevent accidental permanent override of the FTC4.

1. From the service menu use F1 and F2 buttons to scroll through list until Manual Operation is highlighted.
2. Press CONFIRM.
3. Manual operation menu screen is displayed.
4. To activate manual operation press the function button under the desired part.

► Example

Pressing F3 button will switch manual operation mode ON for the main 3-way valve. When filling of the DHW tank is complete the installer should access this menu again and press F3 to deactivate manual operation of the part. Alternatively after 2 hours manual operation mode will no longer be active and FTC4 will resume control of the part.

NOTE: Manual operation and heat source setting can not be selected if the system is running. A screen will be displayed asking the installer to stop the system before these modes can be activated. The system automatically stops 2 hours after last operation.

Auxiliary settings

This function is used to set the parameters for any auxiliary parts used in the system.

From the service menu use F1 and F2 buttons to highlight Auxiliary settings then press CONFIRM.

<Economy settings for pump>

1. From the Auxiliary settings menu highlight Economy Settings for water circulation pump.
2. Press CONFIRM.
3. The economy settings for water circulation pump screen is displayed.
4. Use button F1 to switch the water circulation pump ON/OFF.
5. Use buttons F3 and F4 to adjust the time the water circulation pump will run. (3 - 60 mins)

<Electric heater (Heating)>

1. From the Auxiliary settings menu highlight Electric heater (heating).
2. Press CONFIRM.
3. The Electric heater (heating) screen is displayed.
4. Press F1 button to switch the function ON/OFF.
5. Use F3 and F4 buttons to adjust the time period of heat pump only operation before the booster heater will assist in space heating. (5 -180mins)

<Electric heater (DHW)>

1. From the Auxiliary settings menu highlight Electric heater (DHW).
2. Press CONFIRM.
3. The Electric heater (DHW) screen is displayed.
4. Press F1 button to switch the function ON/OFF.
5. Use F3 and F4 buttons to adjust the time period of heat pump only operation before the booster heater and the immersion heater (if present) will assist in DHW heating. (15 -30mins)

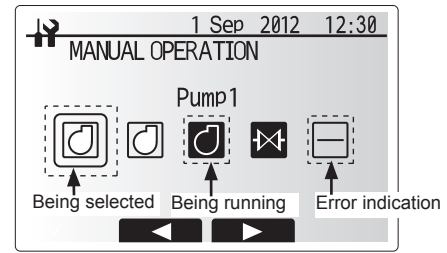

Manual operation menu screen

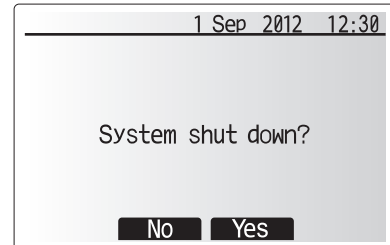

System off prompt screen

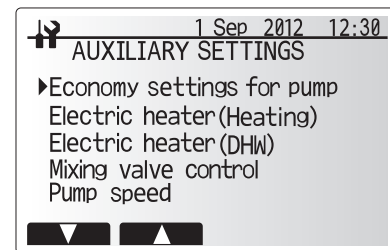

Auxiliary settings menu screen



Economy settings for pump screen

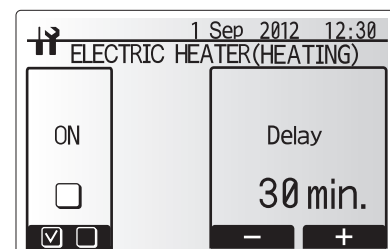

Electric heater (Heating) screen

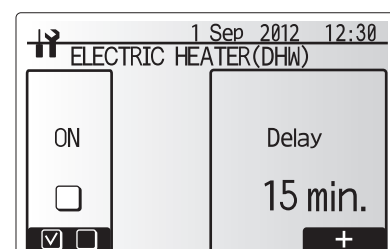

Electric heater (DHW) screen

7. Main controller operation

<Mixing valve control>

1. From the Auxiliary settings menu highlight Mixing valve control.
2. Press CONFIRM.
3. The Mixing valve control screen is displayed.
4. Use F1 and F2 buttons to set Running time between 30 to 240 seconds. The Running time equals to a period from full open of the valve (at a hot water mixing ratio of 100%) to full close (at a cold water mixing ratio of 100%).

Note: Set the Running time according to the specifications of the actuator of each mixing valve.

1. From the Auxiliary settings menu highlight Mixing valve control.
2. Press CONFIRM.
3. The Mixing valve control screen is displayed.
4. Press F3 and F4 buttons to set the interval between 2-zone temperature controls of the mixing valve between 1 to 30 mins.

Note: It is recommended to set the interval to 2 minutes that is a default value. With the interval set longer, it could take longer to warm up a room.



Mixing valve setting screen

<Pump speed>

1. From the Auxiliary settings menu highlight water circulation pump speed.
2. Press CONFIRM.
3. Press F3 and F4 buttons to select a refrigerant address of which you wish to configure or check the settings, and press CONFIRM. *1
4. The Pump speed screen is displayed.
5. Use F2 and F3 buttons to set the pump speed of the water circulation pump between 1 to 5.

*1 For multiple outdoor units control system only.

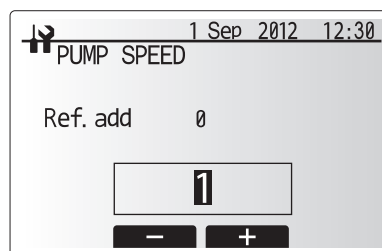

Pump speed setting screen

Heat source setting

The default heat source setting is heat pump and all electric heaters present in the system to be operational. This is referred to as Standard operation on the menu.

1. From the service menu use F1 and F2 buttons to scroll through list until *Heat Source Setting* is highlighted.
2. Press CONFIRM.
3. Heat source setting menu screen is displayed.
4. Press F3 button until preferred heat source is displayed.
5. Press CONFIRM.



Heat source setting screen

6. If you wish to return to the service menu without saving the setting press return button. You will be asked if you are sure you wish to cancel the changes. Choose Yes or No as appropriate.

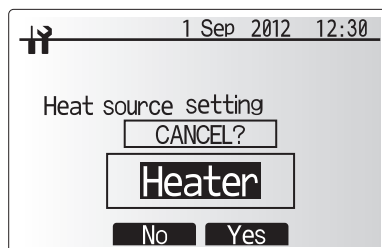

Cancel last action screen

7. Main controller operation

Operation settings

1. To access the Operation settings menu use F1 and F2 buttons to scroll through the service menu until Operation settings is highlighted.
2. Press CONFIRM.
3. Operation settings menu is displayed.

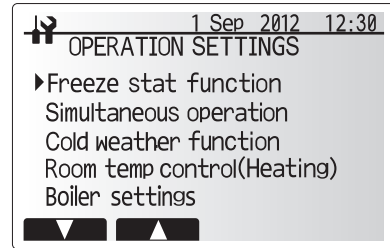

Operation settings menu screen

<Freeze stat function>

1. From the Auxiliary settings menu highlight Freeze Stat Function.
2. Press CONFIRM.
3. The freeze stat function screen will be displayed.
4. Use buttons F3 and F4 to adjust the minimum outdoor ambient temperature which freeze stat function will begin to operate, (3 - 20 °C) or choose *.
If asterisk (*) is chosen freeze stat function is deactivated. (i.e. primary water freeze risk)

Note: When the system is turned off, freeze stat function is not enabled.

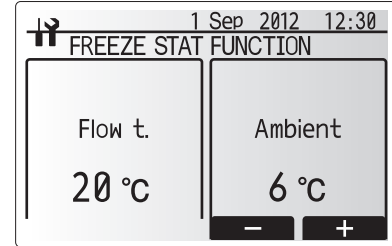

Freeze stat function screen

<Simultaneous Operation>

For periods of very low outside temperature this mode can be used. Simultaneous operation allows both DHW and space heating to run together by using the heat pump and/or booster heater to provide space heating whilst only the immersion heater provides heating for DHW. This operation is only available if BOTH a DHW tank AND immersion heater are present on the system.

1. From the Operation settings menu use F1 and F2 buttons to scroll through the list until Simultaneous operation is highlighted.
2. Press CONFIRM.
3. Simultaneous operation screen is displayed.
4. To switch simultaneous operation ON/OFF press F1.
5. To alter the temperature at which simultaneous operation starts use F3 and F4.

Note:

- Range of outdoor ambient temperature is -15°C to 10°C (default -15°C).
- System shall automatically return to routine operation. This will happen when the outdoor ambient temp rises above the selected temp for this specific mode of operation.

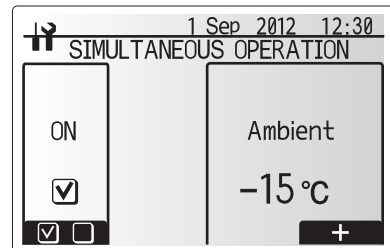

Simultaneous operation screen

<Cold weather function>

For extremely low outdoor ambient temperature conditions when the heat pump's capacity is restricted the heating or DHW is provided only by the electric booster heater (and immersion if present). This function is intended for use during extreme cold periods only. Extensive use of direct electrical heaters ONLY will result in higher electric usage and may reduce working life of heaters and related parts.

1. From the Operation settings menu use F1 and F2 buttons to scroll through the list until Cold weather function is highlighted.
2. Press CONFIRM.
3. Cold weather function screen is displayed.
4. To switch Cold weather function ON/OFF press F1.
5. To alter the temperature at which heater switching function starts use F3 and F4.

Note:

- Range of outdoor ambient temperature is -15°C to -10°C (default -15°C).
- System shall automatically return to routine operation. This will happen when the outdoor ambient temp rises above the selected temp for this specific mode of operation.

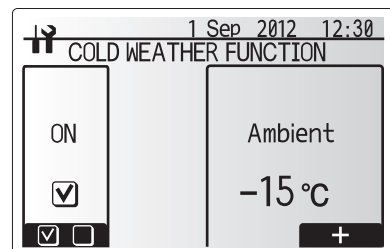

Cold weather function screen

7. Main controller operation

<Room Temp Control (Heating)>

This function allows operational setting of flow temperature range from the Ecodan and also the time interval at which the FTC4 collects and processes data for the auto adaptation mode.

1. From the Operation settings menu use F1 and F2 buttons to scroll through the list until Room temp. control (HEATING) is highlighted.
2. Press CONFIRM.
3. Use F1 and F2 keys to scroll through the menu selecting each subtitle in turn by pressing CONFIRM. See the table below for description of each setting.
4. Enter the desired number using the function keys and press CONFIRM.

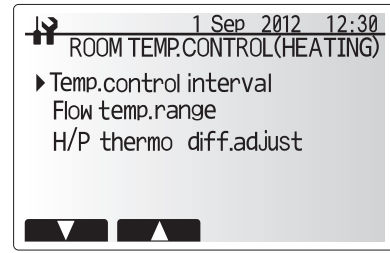

Room temp. control (HEATING) screen

Menu subtitle	Function	Range	Unit	Default	
Temp. control interval	Selectable according to the heat emitter type and the materials of floor (i.e. radiators, floor heating-thick, -thin concrete, wood, etc.)	10 - 60	mins.	10	
Flow temperature range	Minimum temp.	To minimize the loss by frequent ON and OFF in mild outdoor ambient temp. seasons.	25 - 45	°C	30
	Maximum temp.	To set max. possible flow temp according to the type of heat emitters.	35 - 60	°C	50
Heat pump thermo diff.adjust	On/Off	To minimize the loss by frequent ON and OFF in mild outdoor ambient temp. seasons.	On/Off	—	On
	Lower limit	Prohibits heat pump operation until the flow temperature drops below the target flow temperature minus lower limit value.	-9 - -1	°C	-5
	Upper limit	Allows heat pump operation until the flow temperature rises above the target flow temperature plus upper limit value.	+3 - +5	°C	+5

*1 The minimum flow temperature that prohibits heat pump operation is 20°C.

*2 The maximum flow temperature that allows heat pump operation equals to the maximum temperature set in the flow temp. range menu.

<Floor dry up function>

The Floor dry up function automatically changes the target hot water temperature in stages to gradually dry concrete when this particular type of underfloor heating system is installed.

1. Turn off the system using the main controller.
2. From the Operation settings in the service menu, use F1 and F2 buttons to scroll through the list until Floor dry up function is highlighted.
3. Press CONFIRM to display the FLOOR DRY UP screen.
4. To change settings, press F4. For details on settings, refer to the table below.
5. To start the Floor dry up operation, press F1 button to check a box below "Active" and press CONFIRM

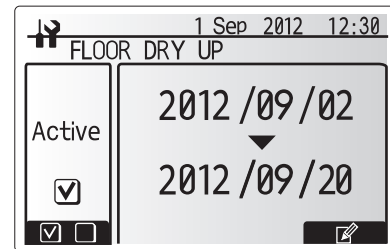

- *1. Upon completion of the operation the system stops all the operations except the Freeze stat. operation.
- *2. For Floor dry up function, the target flow temp. of Zone1 is the same as that of Zone2.

Note:

- This function is not available when a PUAZ-FRP outdoor unit is connected.
- Disconnect wiring to signal inputs of room thermostat, demand control, and outdoor thermostat, or the target flow temp. may not be maintained.

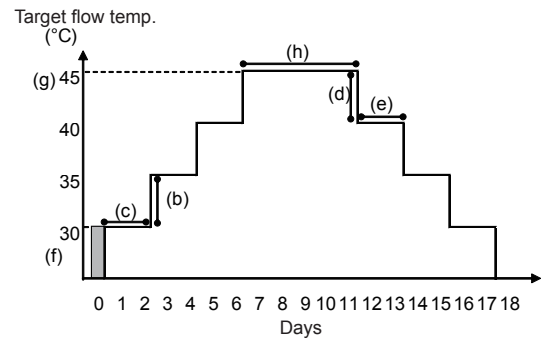

Functions	Symbol	Description	Option/Range	Unit	Default
Floor dry up function	a	Set the function to ON and power on the system using the main controller, and the dry up heating operation will start.	On/Off	-	Off
Flow temp. (increase)	Flow temp. increase step	Sets the increase step of the target flow temp.	+1 - +10	°C	+5
	Increase interval	Sets the period for which the same target flow temp is maintained.	1 - 7	day	2
Flow temp. (decrease)	Flow temp. decrease step	Sets the decrease step of the target flow temp.	-1 - -10	°C	-5
	Decrease interval	Sets the period for which the same target flow temp is maintained.	1 - 7	day	2
Target temperature	Start & Finish	Sets the target flow temp. at the start and the finish of the operation.	25 - 60	°C	30
	Max. target temp.	Sets the maximum target flow temp.	25 - 60	°C	45
	Max. temp. period	Sets the period for which the maximum target flow temp. is maintained.	1 - 20	day	5

7. Main controller operation

External input settings

From the service menu use F1 and F2 buttons to highlight External input settings then press CONFIRM.

<Demand control (IN4)>

1. From the External input settings menu highlight Demand control (IN4).
2. Press CONFIRM.
3. The Demand control screen is displayed.

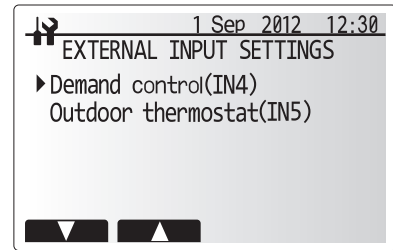

External input settings menu screen

4. Press F3 button to select Heat source OFF or Boiler.
5. Press CONFIRM.

Note: The selection of "OFF", whilst a signal is being sent to IN4, forcefully stops all the heat source operations and the selection of "Boiler" stops operations of heat pump and electric heater and performs boiler operation.

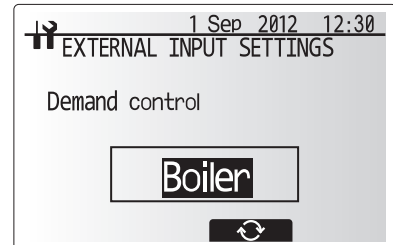

Demand control screen

<Outdoor thermostat (IN5)>

1. From the External input settings menu highlight Outdoor thermostat (IN5).
2. Press CONFIRM.
3. The Outdoor thermostat screen is displayed.
4. Press F3 button to select Heater or Boiler.
5. Press CONFIRM.

Note: The selection of "Heater", whilst a signal is being sent to IN5, performs electric-heater-only operation and the selection of "Boiler" performs boiler operation.

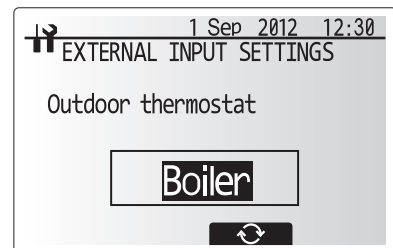

Outdoor thermostat setting screen

Password protection

Password protection is available to prevent unauthorised access to the service menu by untrained persons.

1. From the service menu use F1 and F2 buttons to scroll through list until *Password protection* is highlighted.
2. Press CONFIRM.
3. When password input screen is displayed use buttons F1 and F2 to move left and right between the four digits, F3 to lower the selected digit by 1, and F4 to increase the selected digit by 1.
4. When you have input your password press CONFIRM.



Password input screen

5. The password verify screen is displayed.
6. To verify your new password press button F3.
7. Your password is now set and the completion screen is displayed.



Password verify screen

<Resetting the password>

If you forget the password you entered, or have to service a unit somebody else installed, you can reset the password to the factory default of 0000.

1. From the main settings menu scroll down the functions until Service Menu is highlighted.
2. Press CONFIRM.
3. You will be prompted to enter a password.
4. Hold down buttons F3 and F4 together for 3 secs
5. You will be asked if you wish to continue and reset the password to default setting.
6. To reset press button F3.
7. The password is now reset to 0000.



Completion screen

7. Main controller operation

Manual reset

Should you wish to restore the factory settings at any time you should use the manual reset function. Please note this will reset ALL functions to the factory default settings.

1. From the service menu use F1 and F2 buttons to scroll through list until Manual Reset is highlighted.
2. Press CONFIRM.
3. The Manual reset screen is displayed.
4. Choose either Manual Reset for FTC4 or Main Controller.

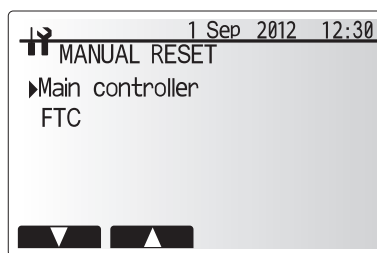

5. Press F3 button to confirm manual reset of chosen device.

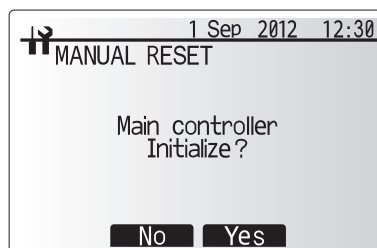

SD card

The use of an SD memory card simplifies the main controller settings in the field.

*Ecodan service tool (for use with PC tool) is necessary for the setting.

<SD → Main RC>

1. From the SD card setting use F1 and F2 buttons to scroll through list until "SD → Main RC" is highlighted.
 2. Press CONFIRM.
 3. Press F3 and F4 buttons to set the Ref. address. *1
 4. Use F1, F2 and F3 buttons to select a menu to write to the main controller.
 5. Press CONFIRM to start downloading.
 6. Wait for a few minutes until "Complete!" appears.
- *1 For multiple outdoor units control system only.

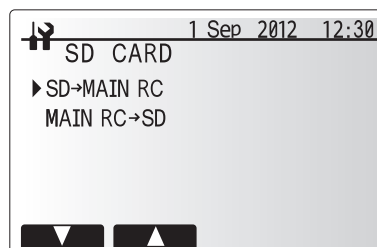

<Main RC → SD>

1. From the SD card setting use F1 and F2 buttons to scroll through list until Main RC → SD is highlighted.
 2. Press CONFIRM.
 3. Press F3 and F4 buttons to set the Ref. address. *1
 4. Use F1, F2 and F3 buttons to select a menu to write to the SD memory card.
 5. Press CONFIRM to start uploading.
 6. Wait for a few minutes until "Complete!" appears.
- *1 For multiple outdoor units control system only.

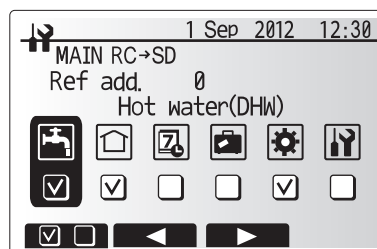
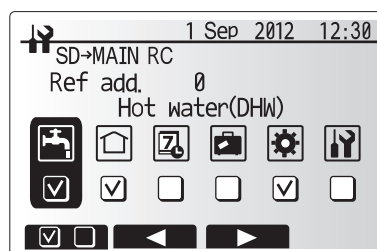

7. Main controller operation

Should settings be changed from default please enter new setting in 'Field Setting' column. This will ease resetting in the future should the system use change or the circuit board need to be replaced.

Commissioning/Field settings record sheet

Main controller screen		Parameters	Default setting	Field setting	Notes	
Main	Zone1 heating room temp		10°C - 30°C	20°C		
	Zone2 heating room temp *1		10°C - 30°C	20°C		
	Zone1 heating flow temp		25°C - 60°C	45°C		
	Zone2 heating flow temp *1		25°C - 60°C	35°C		
	Cooling flow temp *2		5°C - 25°C	15°C		
	Zone1 heating compensation curve		-9°C - + 9°C	0°C		
	Zone2 heating compensation curve *1		-9°C - + 9°C	0°C		
Holiday mode		Active/Non active/Set time	-			
Option	Forced DHW operation		On/Off	-		
	DHW		On/Off/Timer	On		
	Heating		On/Off/Timer	On		
	Holiday mode		Active/Non active/Set time	-		
Setting	DHW *3	Operation mode		Normal/Eco	Normal	
		DHW max. temp.		40°C - 60°C	50°C	
		DHW temp. drop		5°C - 30°C	10°C	
		DHW max. operation time		30 - 120 mins	60 mins	
		DHW mode restriction		30 - 120 mins	30 mins	
		Legionella prevention *3		Active	Yes/No	Yes
	Hot water temp		60°C - 70°C	65°C		
	Frequency		1 - 30 days	15 days		
	Start time		00.00 - 23.00	03.00		
	Max. operation time		1 - 5 hours	3 hours		
	Duration of maximum temp.		1 - 120 mins	30 min		
	Heating/Cooling *2		Zone1 operation mode	Heating room temp/Heating flow temp/Heating compensation curve/Cooling flow temp	Room temp	
			Zone2 operation mode *1	Heating room temp/Heating flow temp/Heating compensation curve	Compensation curve	
	Compensation curve	Hi set point	Zone1 outdoor ambient temp		-15°C - +35°C	-15°C
			Zone1 flow temp		25°C - 60°C	50°C
			Zone2 outdoor ambient temp *1		-15°C - +35°C	-15°C
			Zone2 flow temp *1		25°C - 60°C	40°C
		Lo set point	Zone1 outdoor ambient temp		-15°C - +35°C	35°C
			Zone1 flow temp		25°C - 60°C	25°C
			Zone2 outdoor ambient temp *1		-15°C - +35°C	35°C
			Zone2 flow temp *1		25°C - 60°C	25°C
		Adjust	Zone1 outdoor ambient temp		-14°C - +34°C	-
			Zone1 flow temp		25°C - 60°C	-
			Zone2 outdoor ambient temp *1		-14°C - +34°C	-
			Zone2 flow temp *1		25°C - 60°C	-
	Holiday	DHW *3		Active/Non active	Non active	
		Heating/Cooling *2		Active/Non active	Active	
		Zone1 heating room temp		10°C - 30°C	15°C	
		Zone2 heating room temp *1		10°C - 30°C	15°C	
		Zone1 heating flow temp		25°C - 60°C	35°C	
		Zone2 heating flow temp *1		25°C - 60°C	25°C	
		Cooling flow temp *2		5°C - 25°C	25°C	
		Initial settings		Language	ENG/FR/GER/SW/SP/IT/DA/NL/FIN/NOR/PT	ENG
		°C/°F	°C/°F	°C		
		Temp. display	Room/DHW tank/Room&DHW tank /Off	Off		
		Time display	hh:mm/hh:mm AM/AM hh:mm	hh:mm		
		Room sensor settings for Zone1	TH1/Main RC/Room RC1-8/"Time/Zone"	TH1		
		Room sensor settings for Zone2 *1	TH1/Main RC/Room RC1-8/"Time/Zone"	TH1		
		Room RC zone select *1	Zone1/Zone2	Zone1		
Service menu	Thermistor adjustment	THW1		-10°C - +10°C	0°C	
		THW2		-10°C - +10°C	0°C	
		THW5		-10°C - +10°C	0°C	
		THW6		-10°C - +10°C	0°C	
		THW7		-10°C - +10°C	0°C	
		THW8		-10°C - +10°C	0°C	
		THW9		-10°C - +10°C	0°C	
		THWB1		-10°C - +10°C	0°C	
		THWB2		-10°C - +10°C	0°C	
	Auxiliary settings	Economy settings for pump		On/Off	On	
		Electric heater (Heating)		Time before pump switched off (3 - 60 mins) *4	10 mins	
		Electric heater (DHW) *3		Space heating: On (used)/Off (not used)	On	
				Electric heater delay timer (5 - 180 mins)	30 mins	
				DHW: On (used)/Off (not used)	On	
				Electric heater delay timer (15 - 30 mins)	15 mins	
		Mixing valve control	Running time (10 - 240 secs)	120 secs		
			Interval (1 - 30 mins)	2 mins		
		Pump speed	Pump speed (1 - 5)	5		

*1 The settings related to Zone2 can be switched only when Zone2 temperature control is enabled (when Dip SW2-6 and SW 2-7 are ON).

*2 Cooling mode settings are available for ERSC-VM2B only.

*3 Only available if DHW tank present in system.

*4 Decreasing "time before pump switched off" may increase the duration of stand-by in Heating mode.

7. Main controller operation

Commissioning/Field settings record sheet (continued from the previous page)

Main controller screen		Parameters		Default setting	Field setting	Notes		
Service menu	Heat source setting	Standard/Heater/Boiler/Hybrid *5		Standard				
	Operation settings	Freeze stat function	Outdoor ambient temp. (3 - 20°C)		5°C			
			Simultaneous operation (DHW/ Heating)	On/Off *6		Off		
				Outdoor ambient temp. (-15 - +10°C)		-15°C		
		Cold weather function	On/Off *6		Off			
			Outdoor ambient temp. (-15 - -10°C)		-15°C			
		Room temp control (Heating)	Temp. control interval (10 - 60 mins)		10 mins			
			Flow temp. range	Min. temp. (25 - 45°C)	30°C			
				Max. temp. (35 - 60°C)	50°C			
			Heat pump thermo diff. adjust	On/Off *6		On		
				Lower limit (-9 - -1°C)		-5°C		
		Upper limit (+3 - +5°C)		5°C				
		Boiler operation	Hybrid settings		Outdoor ambient temp. (-15 - +10°C)	-15°C		
					Priority mode (Ambient/Cost/CO ₂)	Ambient		
			Intelligent settings	Energy price *7	Electricity (0.001 - 999 */kWh)	0.5 */kWh		
					Boiler (0.001 - 999 */kWh)	0.5 */kWh		
	CO ₂ emission			Electricity (0.001 - 999 kg -CO ₂ /kWh)	0.5 kg -CO ₂ /kWh			
				Boiler (0.001 - 999 kg -CO ₂ /kWh)	0.5 kg -CO ₂ /kWh			
	Heat source		Heat pump capacity (1 - 40 kW)		11.2 kW			
			Boiler efficiency (25 - 150%)		80%			
			Booster heater 1 capacity (1 - 20 kW)		2 kW			
			Booster heater 2 capacity (1 - 20 kW)		4 kW			
	Floor dry up function	On/Off *6		Off				
		Target temp.	Start&Finish (25 - 60°C)		30°C			
			Max. temp. (25 - 60°C)		45°C			
			Max. temp. period (1 - 20 days)		5 days			
		Flow temp. (Increase)	Temp. increase step (+1 - +10°C)		+5°C			
Increase interval (1 - 7 days)			2 days					
Flow temp. (Decrease)		Temp. decrease step (-1 - -10°C)		-5°C				
	Decrease interval (1 - 7 days)		2 days					
External input settings	Demand control (IN4)	Heat source OFF/Boiler operation		Boiler operation				
	Outdoor thermostat (IN5)	Heater operation/Boiler operation		Boiler operation				

*5 When Dip SW1-1 is set to OFF "WITHOUT Boiler" or SW2-6 is set to OFF "WITHOUT Mixing tank", neither Boiler nor Hybrid can be selected.

*6 On: the function is active; Off: the function is inactive.

7 "" of */kwh" represents currency unit (e.g. € or £ or the like)

8. Troubleshooting

<Troubleshooting by inferior phenomena>

No.	Fault symptom	Possible cause	Explanation - Solution
1	Main controller display is blank.	<ol style="list-style-type: none"> There is no power supply to main controller. Power is supplied to main controller, however, the display on the main controller does not appear. 	<ol style="list-style-type: none"> Check LED2 on FTC4 (Master). (See <Figure 4.5.1>.) <ol style="list-style-type: none"> When LED2 is lit. Check for damage or contact failure of the main controller wiring. When LED2 is blinking. Refer to No. 5 below. When LED2 is not lit. Refer to No. 4 below. Check the following: <ul style="list-style-type: none"> Disconnection between the main controller cable and the FTC4 (Master) control board Failure of the main controller if "Please Wait" is not displayed. Refer to No. 2 below if "Please Wait" is displayed.
2	"Please Wait" remains displayed on the main controller.	<ol style="list-style-type: none"> "Please Wait" is displayed for up to 6 minutes. Communication failure between the main controller and FTC4 (Master). Communication failure between FTC4 (Master) and outdoor unit. 	<ol style="list-style-type: none"> Normal operation. 3. Main controller start up checks/procedure. <ol style="list-style-type: none"> If "0%" or "50-99%" is displayed below "Please Wait" there is a communication error between the main controller and the FTC4 (Master) control board. <ul style="list-style-type: none"> Check wiring connections on the main controller. Replace the main controller or the FTC4 (Master) control board. If "1-49%" is displayed there is a communication error between the outdoor unit's and FTC4 (Master) control boards. <ul style="list-style-type: none"> Check the wiring connections on the outdoor unit control board and the FTC4 (Master) control board. (Ensure S1 and S2 are not cross-wired and S3 is securely wired with no damage. (See section 4.1.) Replace the outdoor unit's and/or the FTC4 (Master) control boards.
3	The main screen appears with a press of the "ON" button, but disappears in a second.	The main controller operations do not work for a whilst after the settings are changed in the service menu. This is because the system takes time to apply the changes.	Normal operation. The indoor unit is applying updated settings made in the service menu. Normal operation will start shortly.
4	LED2 on FTC4 (Master) is off. (See <Figure 4.5.1>.)	<p>When LED1 on FTC4 (Master) is also off. (See <Figure 4.5.1>.) <FTC4 (Master) powered via outdoor unit.></p> <ol style="list-style-type: none"> The outdoor unit is not supplied at the rated voltage. Defective outdoor controller circuit board. FTC4 (Master) is not supplied with 220 to 240V AC. FTC4 (Master) failure. Faulty connector wiring. 	<ol style="list-style-type: none"> Check the voltage across the terminals L and N or L3 and N on the outdoor power board. (See section 4.1.) <ul style="list-style-type: none"> When the voltage is not 220 to 240V AC, check wiring of the outdoor unit and of the breaker. When the voltage is at 220 to 240V AC, go to "2." below. Check the voltage across the outdoor unit terminals S1 and S2. (See section 4.1.) <ul style="list-style-type: none"> When the voltage is not 220 to 240V AC, check the fuse on the outdoor control board and check for faulty wiring. When the voltage is 220 to 240V AC, go to "3." below. Check the voltage across the indoor unit terminals S1 and S2. (See section 4.1.) <ul style="list-style-type: none"> When the voltage is not 220 to 240V AC, check FTC4 (Master)-outdoor unit wiring for faults. When the voltage is 220 to 240V AC, go to "4." below. Check the FTC4 (Master) control board. <ul style="list-style-type: none"> Check the fuse on FTC4 (Master) control board. Check for faulty wiring. If no problem found with the wiring, the FTC4 (Master) control board is faulty. Check the connector wiring. <ul style="list-style-type: none"> When the connectors are wired incorrectly, re-wire the connectors referring to below. (See section 4.1.)

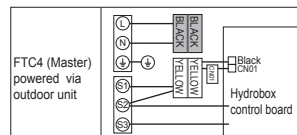

8. Troubleshooting

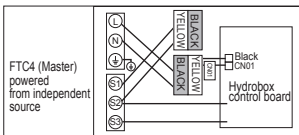
No.	Fault symptom	Possible cause	Explanation - Solution
4.	LED2 on FTC4 (Master) is off. (See Figure <4.5.1>)	<FTC4 (Master) powered on independent source>	<ol style="list-style-type: none"> 1. Check the voltage across the L and N terminals on the indoor power supply terminal block. (See section 4.1.) <ul style="list-style-type: none"> • When the voltage is not 220 to 240V AC, check for faulty wiring to power supply. • When the voltage is 220 to 240V AC, go to 2. below. 2. Check for faulty wiring between the connectors. <ul style="list-style-type: none"> • When the connectors are wired incorrectly re-wire them correctly referring to below. (See section 4.1 and a wiring diagram on the control and electrical box cover.)  <ul style="list-style-type: none"> • If no problem found with the wiring, go to 3. below.
		<ol style="list-style-type: none"> 1. FTC4 (Master) is not supplied with 220 to 240V AC. 2. There are problems in the method of connecting the connectors. 3. FTC4 (Master) failure. 	
		When LED1 on FTC4 (Master) is lit. Incorrect setting of refrigerant address for outdoor unit. (None of the refrigerant address is set to "0".)	Recheck the refrigerant address setting on the outdoor unit. Set the refrigerant address to "0". (Set refrigerant address using SW1(3 - 6) on outdoor controller circuit board.)
5	LED2 on FTC4 (Master) is blinking. (See Figure <4.5.1>)	When LED1 is also blinking on FTC4 (Master). Faulty wiring between FTC4 (Master) and outdoor unit	Check for faulty wiring between FTC4 (Master) and outdoor unit.
		When LED1 on FTC4 (Master) is lit. <ol style="list-style-type: none"> 1. Faulty wiring in main controller Multiple indoor units have been wired to a single outdoor unit. 2. Short-circuited wiring in main controller 3. Main controller failure 	<ol style="list-style-type: none"> 1. Check for faulty wiring in main controller. The number of indoor units that can be wired to a single outdoor unit is one. Additional indoor units must be wired individually to a single outdoor unit. 2,3. Remove main controller wires and check LED2 on FTC4 (Master). (See Figure 4.5.1.) <ul style="list-style-type: none"> • If LED2 is blinking check for short circuits in the main controller wiring . • If LED2 is lit, wire the main controller again and: <ul style="list-style-type: none"> - if LED2 is blinking, the main controller is faulty; - if LED2 is lit, faulty wiring of the main controller has been corrected.
6	LED4 on FTC4 (Master) is off. (See figure <4.5.1>)	<ol style="list-style-type: none"> 1. SD memory card is NOT inserted into the memory card slot with correct orientation. 2. Not an SD standards compliant memory card. 	<ol style="list-style-type: none"> 1. Correctly insert SD memory card in place until a click is heard. 2. Use an SD standards compliant memory card. (Refer to section 4.9.)
	LED4 on FTC4 (Master) is blinking. (See Figure <4.5.1>)	<ol style="list-style-type: none"> 1. Full of data. 2. Write-protected. 3. NOT formatted. 4. Formatted in NTFS file system. 	<ol style="list-style-type: none"> 1. Move or delete data, or replace SD memory card with a new one. 2. Release the write-protect switch. 3. Refer to "4.9 Using SD memory card". 4. FTC4 is Not compatible with NTFS file system. Use an SD memory card formatted in FAT file system.
7	No water at hot tap.	<ol style="list-style-type: none"> 1. Cold main off 2. Strainer (field supply) blocked. 	<ol style="list-style-type: none"> 1. Check and open stop cock. 2. Isolate water supply and clean strainer.
8	Cold water at tap.	<ol style="list-style-type: none"> 1. Hot water run out. 2. Prohibit, schedule timer or holiday mode selected. 3. Heat pump not working. 4. Booster heater cut-out tripped. 5. The earth leakage circuit breaker for booster heater breaker (ECB1) tripped. 6. The booster heater thermal cut-out has tripped and cannot be reset using the manual reset button. 7. Immersion heater cut-out tripped. 8. Immersion heater breaker (ECB2) tripped. 9. 3-way valve fault 	<ol style="list-style-type: none"> 1. Ensure DHW mode is operating and wait for DHW tank to re-heat. 2. Check settings and change as appropriate. 3. Check heat pump – consult outdoor unit service manual. 4. Check booster heater thermostat and press reset button if safe. Reset button is located on the side of booster heater, covered with white rubber cap. See component parts diagram (Installation manual of Hydrobox, section 3.) to find out its position. 5. Check the cause and reset if safe. 6. Check resistance across the thermal cut-out, if open then the connection is broken and the booster heater will have to be replaced. Contact your Mitsubishi Electric dealer. 7. Check immersion heater thermostat and press reset button, located on immersion heater boss, if safe. If the heater has been operated with no water inside it may have failed, so please replace it with a new one. 8. Check the cause and reset if safe. 9. Check plumbing/wiring to 3-way valve. <ol style="list-style-type: none"> (i) Manually override 3-way valve using the main controller. (Refer to <Manual operation> in section 7.2.) If the valve does not still function, go to (ii) below. (ii) Replace 3-way valve coil. If the valve does not still function, go to (iii) below. (iii) Replace 3-way valve. (Refer to the service manual.)

8. Troubleshooting

No.	Fault symptom	Possible cause	Explanation - Solution
9	Water heating takes longer.	<ol style="list-style-type: none"> Heat pump not working. Booster heater cut-out tripped. Booster heater breaker tripped. The booster heater thermal cut-out has tripped and cannot be reset using the manual reset button. Immersion heater cut-out has been triggered. Immersion heater breaker tripped. 	<ol style="list-style-type: none"> Check heat pump – consult outdoor unit service manual. Check booster heater thermostat and press reset button if safe. Reset button is located on the side of booster heater, covered with white rubber cap. See component parts diagram (Installation manual of Hydrobox, section 3.) to find out its position. Check the cause and reset if safe. Check resistance across the thermal cut-out, if open then connection is broken and the booster heater will have to be replaced. Contact your Mitsubishi Electric dealer. Check immersion heater thermostat and press reset button located on immersion heater boss, if safe. If the heater kept running with no water inside, this may have resulted in failure, so replace it with a new one. Check the cause and reset if safe.
10	Temperature of DHW tank water dropped.	<p>When DHW operation is not running, the DHW tank emits heat and the water temperature decreases to a certain level. If water in the DHW tank is reheated frequently because of a significant drop in water temperature, check for the following.</p> <ol style="list-style-type: none"> Water leakage in the pipes that connect to the DHW tank Insulation material coming loose or off. 3-way valve failure 	<ol style="list-style-type: none"> Take the following measures. <ul style="list-style-type: none"> Retighten the nuts holding the pipes onto the DHW tank. Replace seal materials. Replace the pipes. Fix insulation. Check plumbing/wiring to 3-way valve. <ol style="list-style-type: none"> Manually override 3-way valve using the main controller. (Refer to <Manual operation> in section 7.2.) If the valve does not still function, go to (ii) below. Replace 3-way valve coil. If the valve does not still function, go to (iii) below. Replace 3-way valve. (Refer to the service manual.)
11	Hot or warm water from cold tap.	Heat of hot water pipe is transferred to cold water pipe.	Insulate/re-route pipework.
12	Water leakage	<ol style="list-style-type: none"> Poorly sealed connections of water circuit components Water circuit components reaching the end of life 	<ol style="list-style-type: none"> Tighten connections as required. Refer to PARTS CATALOG in the service manual for expected part lifetimes and replace them as necessary.
13	Heating system does not reach the set temperature.	<ol style="list-style-type: none"> Prohibit, schedule timer or holiday mode selected. Check settings and change as appropriate. The temperature sensor is located in a room that has a different temperature relative to that of the rest of the house. Heat pump not working. Booster heater cut-out tripped. Booster heater breaker (ECB1) tripped. The booster heater thermal cut-out tripped and can not be reset using the manual reset button. Incorrectly sized heat emitter. 3-way valve failure Battery problem (*wireless control only) If a mixing tank is installed, the flow rate between the mixing tank and the hydrobox is less than that between the mixing tank and the local system. 	<ol style="list-style-type: none"> Check settings and change as appropriate. Check the battery power and replace if flat. Relocate the temperature sensor to a more suitable room. Check heat pump – consult outdoor unit service manual. Check booster heater thermostat and press reset button if safe. Reset button is located on the side of booster heater, covered with white rubber cap. (See component parts diagram in Installation manual of Hydrobox, section 3. for position.) Check the cause of the trip and reset if safe. Check resistance across the thermal cut-out, if open then the connection is broken and the booster heater will have to be replaced. Contact your Mitsubishi Electric dealer. Check the heat emitter surface area is adequate. Increase size if necessary. Check plumbing/wiring to 3-way valve. Check the battery power and replace it flat. Increase the flow rate between the mixing tank and the hydrobox decrease that between the mixing tank and the local system.

8. Troubleshooting

No.	Fault symptom	Possible cause	Explanation - Solution
14	In 2-zone temperature control, only Zone2 does not reach the set temperature.	<ol style="list-style-type: none"> When Zone1 and Zone2 are both in heating mode, the hot water temperature in Zone2 does not exceed that in Zone1. Faulty wiring of motorized mixing valve Faulty installation of motorized mixing valve Incorrect setting of Running time Motorized mixing valve failure 	<ol style="list-style-type: none"> Normal action no action necessary. Refer to "5.3 Wiring for 2-zone temperature control". Check for correct installation. (Refer to the manual included with each motorized mixing valve.) Check for correct setting of Running time. Inspect the mixing valve. (Refer to the manual included with each motorized mixing valve.)
15	When a PUHZ-FRP outdoor unit is connected, DHW or Heating operation cannot run.	The outdoor unit is set to have operation of the indoor unit of air conditioner take precedence over that of the hydrobox, and in the main controller settings "Electric heater (Heating)" or "Electric heater (DHW)" is turned off.	Turn ON Electric heater (Heating) or Electric heater (DHW) using the main controller.
16	When a PUHZ-FRP outdoor unit is connected, DHW or Heating operation cannot run.	When the outdoor unit is set to have cooling operation of the indoor unit of air conditioner take precedence over that of the hydrobox, the outdoor unit controls the frequency of the compressor according to the load of air conditioner. The DHW and heating run according to that frequency.	Normal operation no action necessary. If Air-to-Water system is given priority in operation, comp Hz can be regulated depending on the load of DHW or Heating. For more details, refer to the PUHZ-FRP installation manual.
17	After DHW operation room temperature rises slightly.	At the end of the DHW mode operation the 3-way valve diverts hot water away from the DHW circuit into space heating circuit. This is done to prevent the hydrobox components from overheating. The amount of hot water directed into the space heating circuit varies according to the type of the system and of the pipe run between the plate heat exchanger and the hydrobox.	Normal operation no action necessary.
18	The room temperature rises during DHW operation.	3-way valve failure	Check the 3-way valve.
19	Water discharges from pressure relief valve. (Primary circuit)	<ol style="list-style-type: none"> If continual – pressure relief valve may be damaged. If intermittent – expansion vessel charge may have reduced/bladder perished. 	<ol style="list-style-type: none"> Turn the handle on the pressure relief valve to check for foreign objects in it. If the problem is not still solved, replace the pressure relief valve with a new one. Check pressure in expansion vessel. Recharge to 1 bar if necessary. If bladder perished replace expansion vessel with a new one.
20	Water discharges from pressure relief valve (field supplied item). (Sanitary circuit)	<ol style="list-style-type: none"> If continual – field supplied pressure reducing valve not working. If continual – pressure relief valve seat may be damaged. If intermittent – expansion vessel charge may have reduced/bladder perished. DHW tank may have subjected to backflow. 	<ol style="list-style-type: none"> Check function of pressure reducing valve and replace if necessary. Turn the handle on the pressure relief valve to check for foreign objects inside. If the problem is not still solved, replace the pressure relief valve. Check gas-side pressure in expansion vessel. Recharge to correct precharge pressure if necessary. If bladder perished replace expansion vessel with a new one with appropriate pre-charge. Check gas-side pressure in DHW tank. If pressure in DHW tank is similar to that in incoming mains, cold water supply that merges with incoming mains water supply could flow back to DHW tank. Investigate source of back-feed and rectify error in pipework/fitting configuration. Adjust pressure in cold supply.
21	Noisy water circulation pump	Air in water circulation pump .	Use manual and automatic air vents to remove air from system. Top up water if necessary to achieve 1 bar on primary circuit.
22	Noise during hot water draw off typically worse in the morning.	<ol style="list-style-type: none"> Loose airing cupboard pipework. Heaters switching on/off. 	<ol style="list-style-type: none"> Install extra pipe fastening clips. Normal operation no action necessary.
23	Mechanical noise heard coming from the hydrobox.	<ol style="list-style-type: none"> Heaters switching on/off. 3-way valve changing position between DHW and heating mode. 	Normal operation no action necessary.
24	Water circulation pump runs for a short time unexpectedly .	Water circulation pump jam prevention mechanism (routine) to inhibit the build-up of scale.	Normal operation no action necessary.
25	Milky/Cloudy water (Sanitary circuit)	Oxygenated water	Water from any pressurised system will release oxygen bubbles when water is running. The bubbles will settle out.
26	Heating mode has been on standby for a long time (does not start operation smoothly.)	The time of "Delay" set in "Economy settings for pump" is too short. (Go to "Service menu" → "Auxiliary settings" → "Economy settings for pump").	Increase the time of "Delay" in "Economy settings for pump" .

8. Troubleshooting

No.	Fault symptom	Possible cause	Explanation - Solution
27	The hydrobox that was running in the heating mode before power failure is running in the DHW mode after power recovery.	The hydrobox is designed to run in an operation mode with a higher priority (i.e. DHW mode in this case) at power recovery.	<ul style="list-style-type: none"> • Normal operation. • After the DHW max. operation time has elapsed or the DHW max. temperature has been reached, the DHW mode switches to the other mode (ex. Heating mode).
28	Cooling mode is NOT available.	Dip SW2-4 is OFF.	Turn Dip SW2-4 to ON. (Refer to "5.1 Dip Switch Functions" in this manual.)
29	The cooling system does not cool down to the set temperature.	<ol style="list-style-type: none"> 1. When the water in the circulation circuit is unduly hot, Cooling mode starts with a delay for the protection of the outdoor unit. 2. When the outdoor temperature is lower than the preset temperature below which the freeze stat. function is activated, Cooling mode does not start running. 	<ol style="list-style-type: none"> 1. Normal operation. 2. To run Cooling mode overriding the freeze stat. function, adjust the preset temperature below which the freeze stat. function is activated. (Refer to "<Freeze stat function>" on Page 49.
30	The electric heaters are activated shortly after DHW or LP mode starts running after Cooling mode.	The setting time period of Heat-pump-only operation is short.	Adjust the setting time period of Heat-pump only operation. (Refer to "<Electric heater (DHW)>" on Page 47.
31	During DHW or LP mode following the cooling mode, error L6 (circulation water freeze protection) occurs and operation stops frequently.	If the preset temperature below which the freeze stat. function is activated is low, error L6 is more likely to occur interruption operation before the freeze stat. function is activated.	Adjust the preset temperature below which the freeze stat. function is activated. (Refer to "<Freeze stat function>" on Page 49.

9. Multiple outdoor units control

9.1 Wiring for multiple outdoor units control

To establish a larger system, up to 6 outdoor units of the same model can be connected in one system.

Note: PUHZ-FRP outdoor unit is not available for multiple outdoor units control.

9.1.1 Requirements

<Outdoor unit>

- (a) Up to 6 units can be connected.
- (b) All the outdoor units must be of the same model.
- (c) The outdoor units must be connected to slave units.

<FTC: Master unit>

Each slave unit is controlled by the master unit.

- (a) The outdoor units must NOT be connected to the master unit.
Make sure that the master unit is powered by independent source.
- (b) Wire the main controller to TBl.2 13-14 on the master unit.
- (c) Wire the electric heater to the master unit.

<FTC: Slave unit>

The hydrobox or PAC-SIF051B-E is used as a slave unit

- (a) Connect each outdoor unit to a slave unit.
- (b) The main controller must NOT be wired to a slave unit.

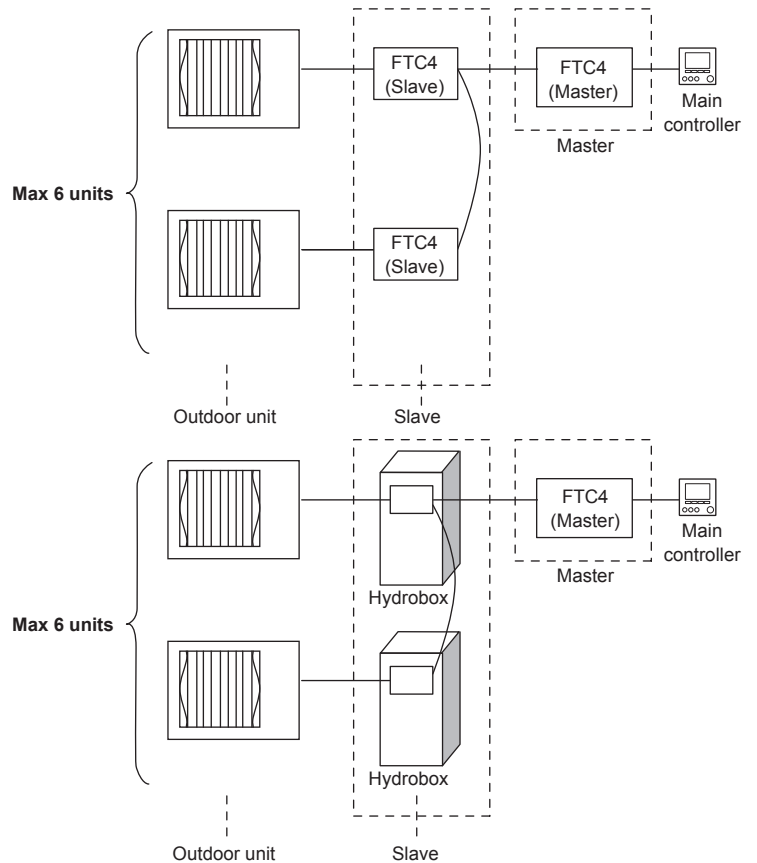

9. Multiple outdoor units control

9.2 Pipe work

Following is the system example of two outdoor units being connected in one system.

IMPORTANT NOTE

Keep the minimum amount of water required in the space heating circuit according to the number of outdoor units.

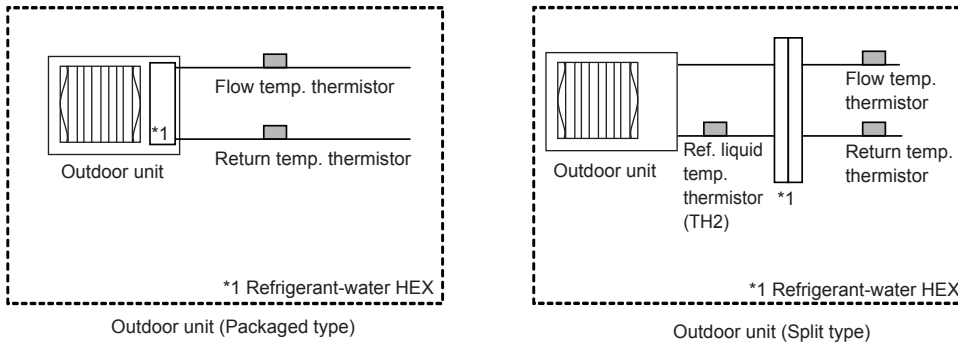

<Fig. 9.2.1>

System 1: Heating/Cooling system

- Install a low loss header (field supply).
- Install booster heater toward the local system, relative to the low loss header.

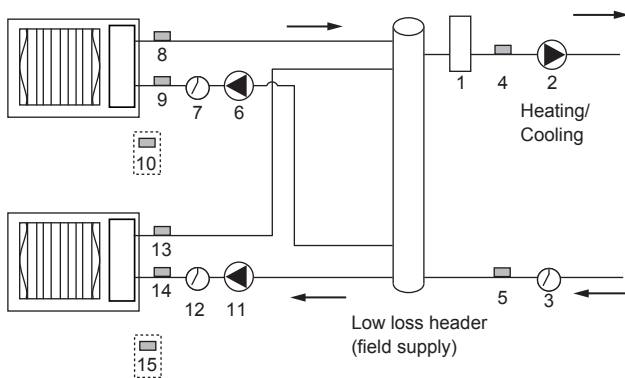

<Fig. 9.2.2>

No.	Component	Wiring		
		Master	Slave 1	Slave 2
1	Booster heater (field supply)	✓		
2	Circulation pump1 (field supply)	✓		
3	Flow switch1 (field supply) *2	✓		
4	Flow temp. thermistor (THW1)	✓		
5	Return temp. thermistor (THW2)	✓		
6	Slave1 circulation pump1 (field supply)		✓	
7	Slave1 flow switch (field supply) *2		✓	
8	Slave1 flow temp. thermistor (THW1)		✓	
9	Slave1 return temp. thermistor (THW2)		✓	
10	Slave1 ref. liquid temp. thermistor (TH2) *1		✓	
11	Slave2 circulation pump1 (field supply)			✓
12	Slave2 flow switch (field supply) *2			✓
13	Slave2 flow temp. thermistor (THW1)			✓
14	Slave2 return temp. thermistor (THW2)			✓
15	Slave2 ref. liquid temp. thermistor (TH2) *1			✓

*1 When the outdoor unit is split type, TH2 needs to be installed. <Fig. 9.2.1>

*2 For safety protection, it is recommended to install a flow switch.

System 2: Heating/Cooling & DHW system

- Install DHW tank toward the outdoor unit, relative to the low loss header.
- Wire 3-way valve (or 2-way valve 1, 2 to FTC (slave unit)).
- LP mode uses assistance of electric heater. Place an immersion heater on the DHW circuit.
- Install a low loss header (field supply).
- Install booster heater toward the local system, relative to the low loss header.

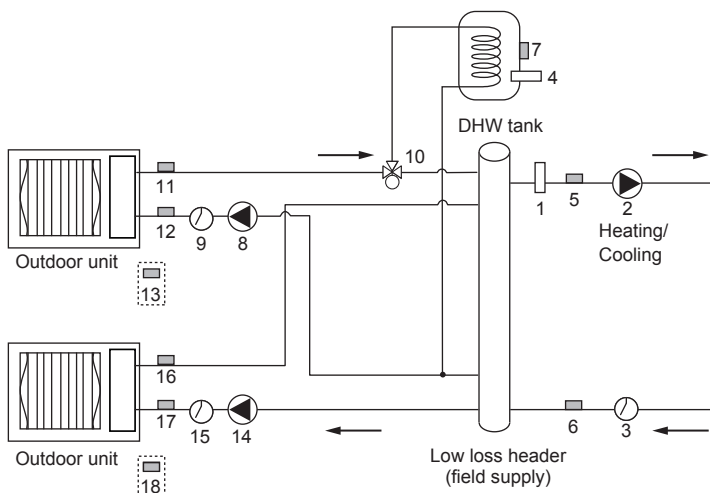

<Fig. 9.2.3>

No.	Component	Wiring		
		Master	Slave 1	Slave 2
1	Booster heater (field supply)	✓		
2	Circulation pump1 (field supply)	✓		
3	Flow switch1 (field supply) *2	✓		
4	Immersion heater (field supply)	✓		
5	Flow temp. thermistor (THW1)	✓		
6	Return temp. thermistor (THW2)	✓		
7	Tank water temp. (THW5)	✓		
8	Slave1 circulation pump1 (field supply)		✓	
9	Slave1 flow switch (field supply) *2		✓	
10	Slave1 3-way valve (field supply) *3		✓	
11	Slave1 flow temp. thermistor (THW1)		✓	
12	Slave1 return temp. thermistor (THW2)		✓	
13	Slave1 ref. liquid temp. thermistor (TH2) *1		✓	
14	Slave2 circulation pump1 (field supply)			✓
15	Slave2 flow switch (field supply) *2			✓
16	Slave2 flow temp. thermistor (THW1)			✓
17	Slave2 return temp. thermistor (THW2)			✓
18	Slave2 ref. liquid temp. thermistor (TH2) *1			✓

*1 When the outdoor unit is split type, TH2 needs to be installed. <Fig. 9.2.1>

*2 For safety protection, it is recommended to instal a flow switch.

*3 The use of two 2-way valves can perform the same function as a 3-way valve.

9. Multiple outdoor units control

System 3: 2-zone temperature control

- Install a mixing tank (field supply) for 2-zone temperature control.
- Install a low loss header (field supply).
- Install booster heater toward the local system, relative to the low loss header.
- For details on 2-zone installation, refer to "3.6 Piping".

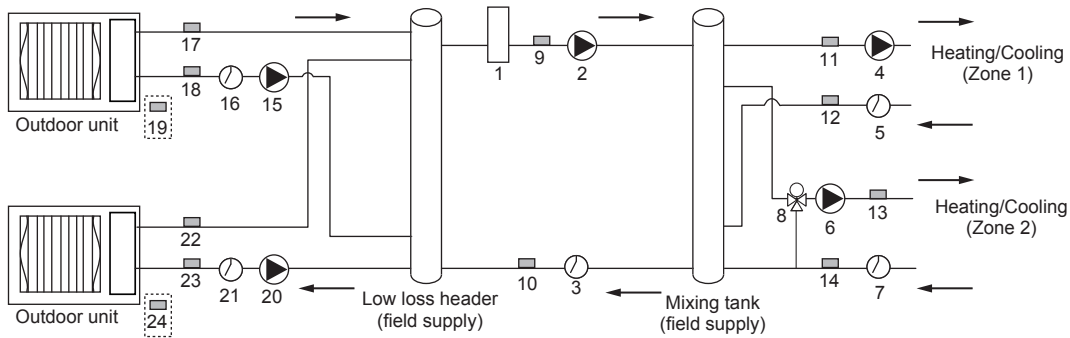

<Fig. 9.2.4>

No.	Component	Wiring		
		Master	Slave 1	Slave 2
1	Booster heater (field supply)	✓		
2	Circulation pump1 (field supply)	✓		
3	Flow switch1 (field supply) *2	✓		
4	Circulation pump2 (field supply)	✓		
5	Flow switch2 (field supply) *2	✓		
6	Circulation pump3 (field supply)	✓		
7	Flow switch3 (field supply) *2	✓		
8	Motorized mixing valve (field supply)	✓		
9	Flow temp. thermistor (THW1)	✓		
10	Return temp. thermistor (THW2)	✓		
11	Zone1 flow temp. thermistor (THW6) (option)	✓		
12	Zone1 return temp. thermistor (THW7) (option)	✓		

No.	Component	Wiring		
		Master	Slave 1	Slave 2
13	Zone2 flow temp. thermistor (THW8) (option)	✓		
14	Zone2 return temp. thermistor (THW9) (option)	✓		
15	Slave1 circulation pump1 (field supply)		✓	
16	Slave1 flow switch (field supply) *2		✓	
17	Slave1 flow temp. thermistor(THW1)		✓	
18	Slave1 return temp. thermistor (THW2)		✓	
19	Slave1 ref. liquid temp. thermistor (TH2) *1		✓	
20	Slave2 circulation pump1 (field supply)			✓
21	Slave2 flow switch (field supply) *2			✓
22	Slave2 flow temp. thermistor (THW1)			✓
23	Slave2 return temp. thermistor (THW2)			✓
24	Slave2 ref. liquid temp. thermistor (TH2) *1			✓

*1 When the outdoor unit is split type, TH2 needs to be installed. <Fig. 9.2.1>

*2 For safety protection, it is recommended to install a flow switch.

9. Multiple outdoor units control

System 4: Heating/Cooling system (with Boiler)

- Install a mixing tank (field supply) for connection of the boiler.
- Install a low loss header (field supply).
- Install booster heater between low loss header and mixing tank.
- For more details, refer to the installation manual of PAC-TH011HT-E.

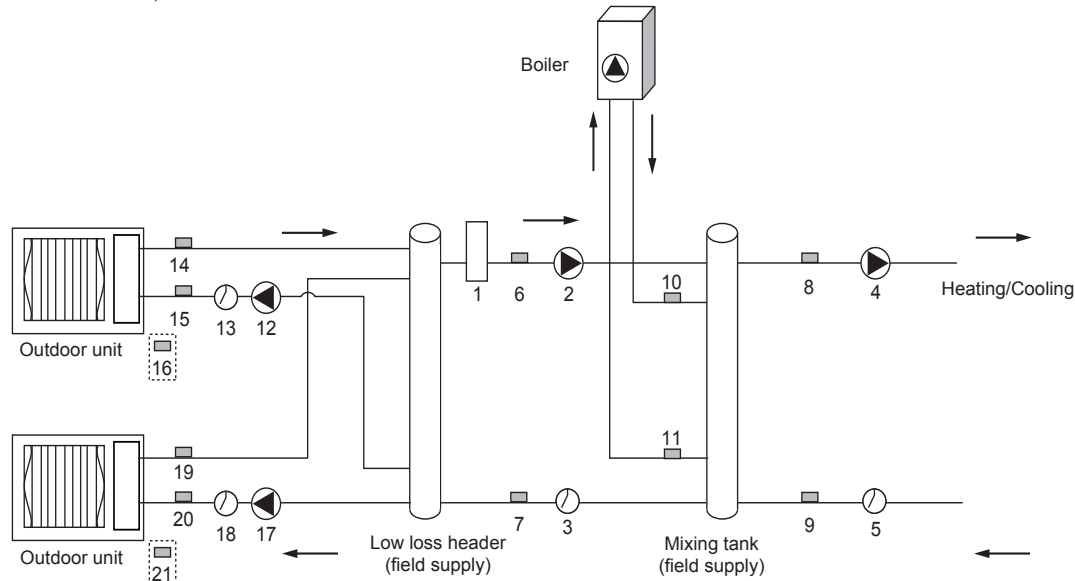

<Fig. 9.2.5>

No.	Component	Wiring		
		Master	Slave 1	Slave 2
1	Booster heater (field supply)	✓		
2	Circulation pump1 (field supply)	✓		
3	Flow switch1 (field supply) *2	✓		
4	Circulation pump2 (field supply)	✓		
5	Flow switch2 (field supply) *2	✓		
6	Flow temp. thermistor (THW1)	✓		
7	Return temp. thermistor (THW2)	✓		
8	Flow temp. thermistor (THW6) (option)	✓		
9	Return temp. thermistor (THW7) (option)	✓		
10	Boiler flow temp. thermistor (THWB1) (option)	✓		

*1 When the outdoor unit is split type, TH2 needs to be installed. <Fig. 9.2.1>

*2 For safety protection, it is recommended to instal a flow switch.

System 5: Heating/Cooling system (with Hydrobox)

- Install a low loss header (field supply).
- Install booster heater toward the local system, relative to the low loss header.

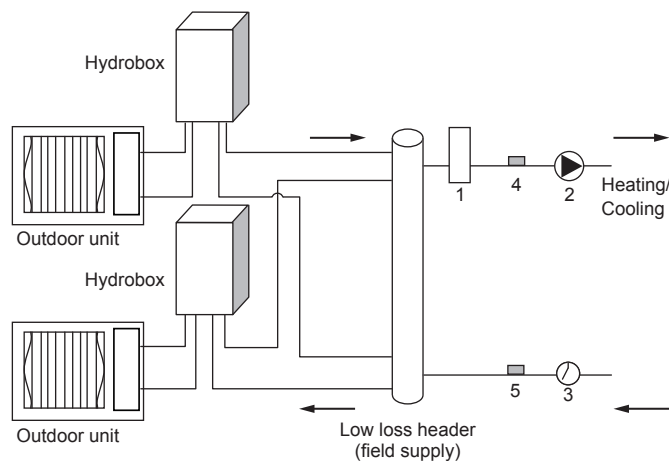

<Fig. 9.2.6>

No.	Component	Wiring		
		Master	Slave 1	Slave 2
11	Boiler return temp. thermistor (THWB2) (option)	✓		
12	Slave1 circulation pump1 (field supply)		✓	
13	Slave1 flow switch (field supply) *2		✓	
14	Slave1 flow temp. thermistor (THW1)		✓	
15	Slave1 return temp. thermistor (THW2)		✓	
16	Slave1 ref. liquid temp. thermistor (TH2) *1		✓	
17	Slave2 circulation pump1 (field supply)			✓
18	Slave2 flow switch (field supply) *2			✓
19	Slave2 flow temp. thermistor (THW1)			✓
20	Slave2 return temp. thermistor (THW2)			✓
21	Slave2 ref. liquid temp. thermistor (TH2) *1			✓

No.	Component	Wiring		
		Master	Slave 1 (Hydrobox)	Slave 2 (Hydrobox)
1	Booster heater(field supply)	✓		
2	Circulation pump1 (field supply)	✓		
3	Flow switch1 (field supply) *2	✓		
4	Flow temp. thermistor (THW1)	✓		
5	Return temp. thermistor (THW2)	✓		

*2 For safety protection, it is recommended to instal a flow switch.

9. Multiple outdoor units control

9.3 Electrical connection

All electrical work should be carried out by a suitably qualified technician. Failure to comply with this could lead to electrocution, fire, and death. It will also invalidate product warranty. All wiring should be according to national wiring regulations.

9.3.1 Master unit

■ FTC4 (Master)

Outdoor unit must NOT be connected to FTC4 (Master) unit.

FTC4 (Master) unit electrical box connector connections changed (see Fig. 9.3.2.)

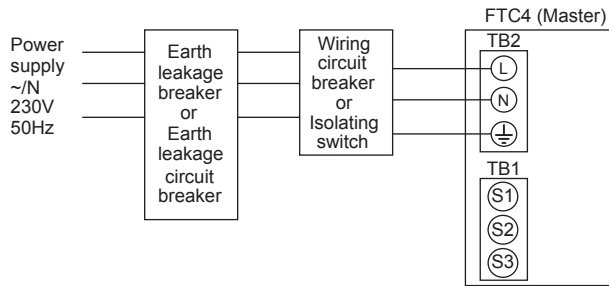

<Fig. 9.3.1>

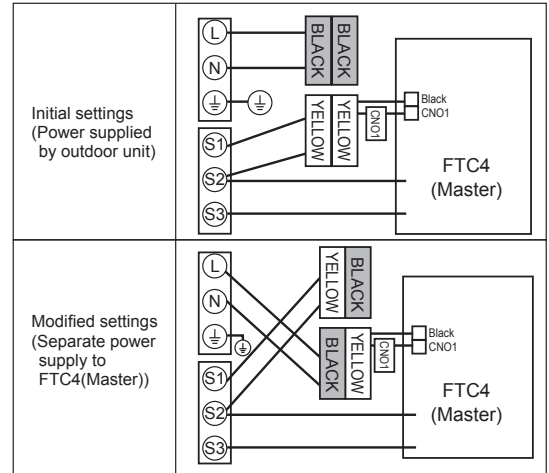

<Fig. 9.3.2>

9. Multiple outdoor units control

9.3.2 Slave unit

Connect each outdoor unit to a slave unit.

FTC4 (Slave) can be powered in two ways.

1. Power cable is run from the outdoor unit to a slave unit.
2. FTC (Slave) has independent power source.

■ FTC4 (Master) (PAC-IF051B-E) used as slave

• For wiring as a slave controller, refer to "4.1 Electrical connection". *1

*1 Don't connect the power cable to the booster heater because it doesn't work in slave controller setting.

■ FTC4 (Slave) (PAC-SIF051B-E) <Fig. 9.3.3>

FTC4 (Slave) can be powered in two ways.

1. Power cable is run from the outdoor unit to FTC4 (Slave).
2. FTC4 (Slave) has independent power source

Note:

- Do not run the low voltage cables through a slot that the high voltage cables go through.
- Bundle cables by using clamps as shown in the figure to the right .

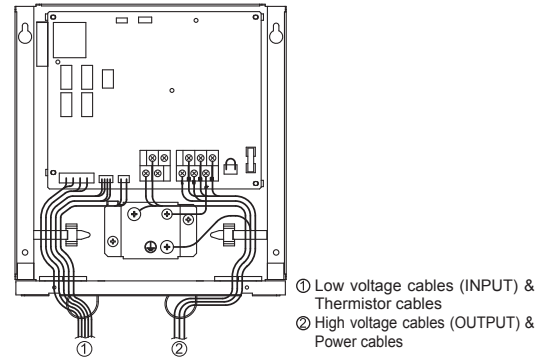

<Fig. 9.3.3>

Option 1: FTC4 (Slave) powered via outdoor unit

<1 phase>

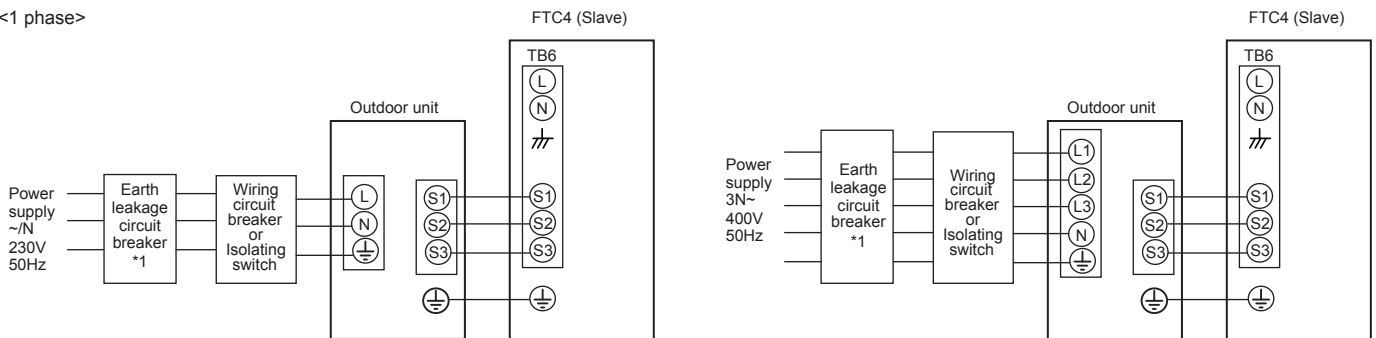

<Fig. 9.3.4>

*1 If the installed earth leakage circuit breaker does not have an over-current protection function, install a breaker with that function along the same power line.

Note: In accordance with IEE regulations the circuit breaker/isolating switch located on the outdoor unit should be installed with lockable devices (health and safety).

Wiring No. Wiring size (mm ²)	FTC4 (Slave) - Outdoor unit		3 × 1.5 (polar)
	FTC4 (Slave) - Outdoor unit earth	*2	1 × Min. 1.5
Circuit rating	FTC4 (Slave) - Outdoor unit S1 - S2	*3	230V AC
	FTC4 (Slave) - Outdoor unit S2 - S3	*3	24V DC

*1. A breaker with at least 3.0 mm contact separation in each pole shall be provided. Use earth leakage breaker (NV).
The breaker shall be provided to ensure disconnection of all active phase conductors of the supply.

*2. Max. 45 m

If 2.5 mm² used, Max. 50 m

If 2.5 mm² used and S3 separated, Max. 80 m

*3. The values given in the table above are not always measured against the ground value.

Notes: 1. Wiring size must comply with the applicable local and national codes.

2. FTC4 (Slave)/outdoor unit connecting cords shall not be lighter than polychloroprene sheathed flexible cord. (Design 60245 IEC 57)

FTC4 (Slave) power supply cords shall not be lighter than polychloroprene sheathed flexible cord. (Design 60227 IEC 53)

3. Install an earth longer than other cables.

9. Multiple outdoor units control

Option 2: FTC4 (Slave) powered by independent source

If FTC4 (Slave) and outdoor units have separate power supplies, the following requirements MUST be carried out:

- Remove the short-circuited connector (CNS2) on FTC4 (Slave) (see <Fig. 9.3.5>.)
- Turn the outdoor unit DIP switch SW8-3 to ON
- Turn on the outdoor unit BEFORE the FTC4 (Slave).

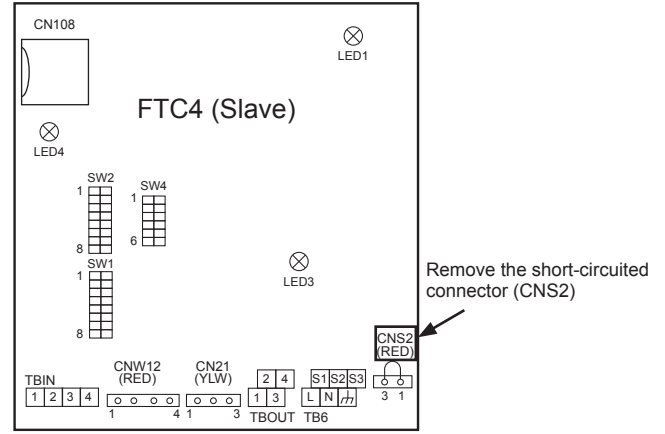

<Fig. 9.3.5>

<1 phase>

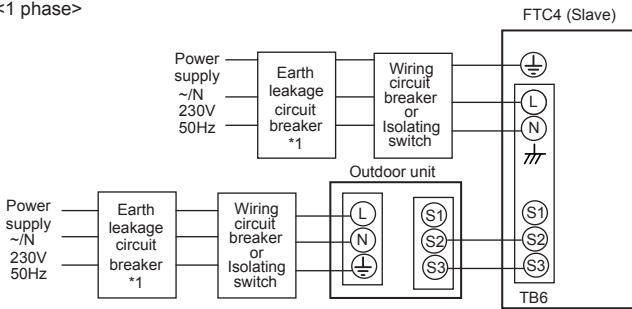

<3 phase>

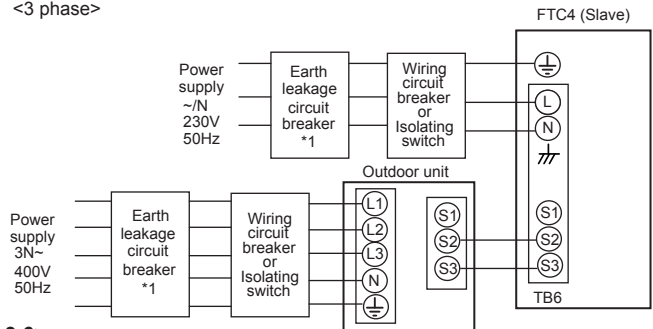

<Fig. 9.3.6>

*1 If the installed earth leakage circuit breaker does not have an over-current protection function, install a breaker with that function along the same power line.

FTC4 (Slave) power supply		~N 230 V 50 Hz
FTC4 (Slave) input capacity		16 A
Main switch (Breaker)		*1
Wiring No. Wiring size (mm ²)	FTC4 (Slave) power supply	2 × Min. 1.5
	FTC4 (Slave) power supply earth	1 × Min. 1.5
	FTC4 (Slave) - Outdoor unit	*2
	FTC4 (Slave) - Outdoor unit earth	—
Circuit rating	FTC4 (Slave) L - N	*3
	FTC4 (Slave) - Outdoor unit S1 - S2	*3
	FTC4 (Slave) - Outdoor unit S2 - S3	*3
		24V DC

*1. A breaker with at least 3.0 mm contact separation in each pole shall be provided. Use earth leakage breaker (NV). The breaker shall be provided to ensure disconnection of all active phase conductors of the supply.

*2. Max. 45 m

If 2.5 mm² used, Max. 50 m

If 2.5 mm² used and S3 separated, Max. 80 m

*3. The values given in the table above are not always measured against the ground value.

- Notes:**
1. Wiring size must comply with the applicable local and national codes.
 2. FTC4 (Slave)/outdoor unit connecting cords shall not be lighter than polychloroprene sheathed flexible cord. (Design 60245 IEC 57)
FTC4 (Slave) power supply cords shall not be lighter than polychloroprene sheathed flexible cord. (Design 60227 IEC 53)
 3. Install an earth longer than other cables.

Hydrobox

• For wiring as a slave controller (hydrobox), refer to "4.5 Electrical Connection" in Hydrobox installation manual. *1

*1 Don't connect the power cable to the booster heater because it doesn't work in slave controller setting.

*2 Don't connect the main controller cable.

<Before system set up>

Insert the included SD memory card into the FTC4 control board. (Refer to section 4.9.)

9. Multiple outdoor units control

9.4 Main controller wiring

(a) Wire the main controller to TBI.2 RC terminals on the master unit. The main controller must NOT be connected to a slave unit.

(b) Use the daisy chain wiring method to wire the master unit and slave units by connecting TBI.2 RC terminals. *1

*1 The maximum length between each units wiring is 10 m. The maximum length of total daisy-chain wiring is 500 m.

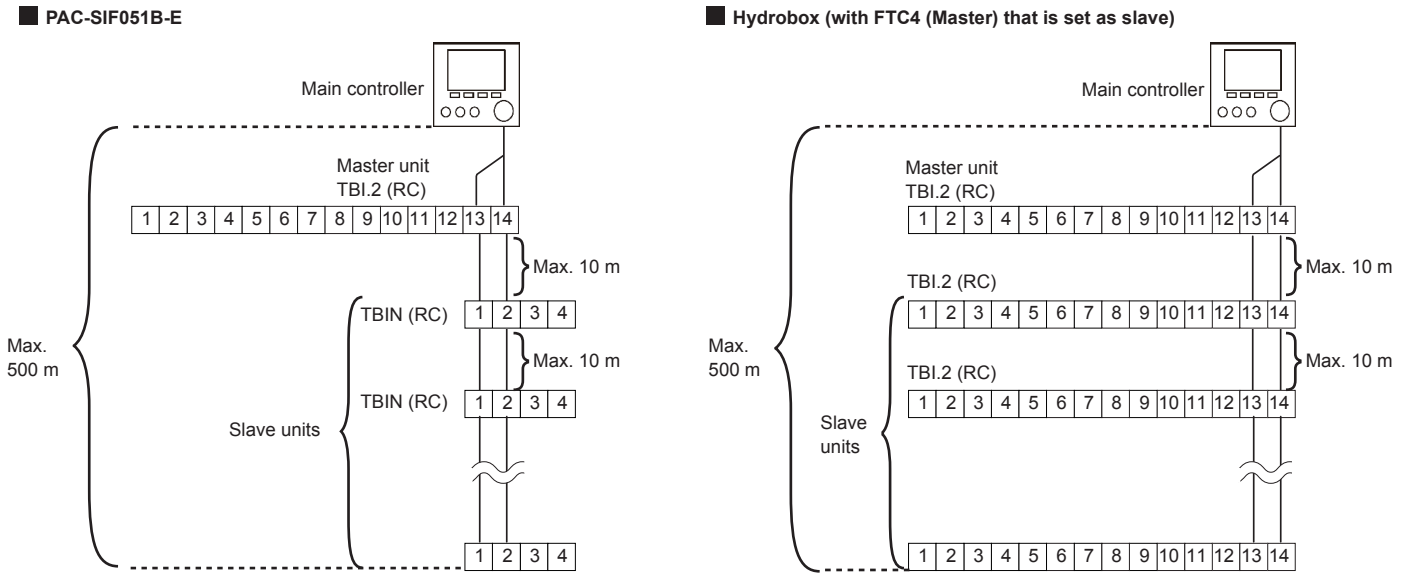

<Fig. 9.4.1>

Note: Wiring for main controller cable and daisy chain cable shall be (5 cm or more) apart from power source wiring so that it is not influenced by electrical noise from power source wiring. (Do NOT insert main controller cable and power source wiring in the same conduit.)

9.5. Connecting the thermistor cables

Connect the thermistor for the FTC4 (Slave) controller.

9.5.1. Connecting the refrigerant pipe temp. thermistor (TH2) cable

Connect the TH2 cable to the CN21 connector on FTC4 (Slave).

For split Outdoor unit : Connect TH2.

For packaged Outdoor unit : It is NOT necessary to connect TH2.

When the TH2 cable is too long, bundle the excess cable outside the FTC4 (Slave) unit.

Do not bind the wires in the FTC4 (Slave) unit.

<Thermistor position>

Place TH2 on **refrigerant** piping (**liquid** side).

It is recommended to protect the thermistor with heat insulating materials so as not to be affected by ambient temperature.

Note: Be sure to place TH2 where it correctly detects refrigerant piping temp. (liquid side).

Because;

- (1) TH2 is required to detect heating subcool correctly.
- (2) Refrigerant temperature of water-to-refrigerant heat exchanger also needs to be detected for protection purpose.

9.5.2. Connecting the flow water temp. thermistor (THW1) cable and the return water temp. thermistor (THW2) cable

The THW1 and the THW2 cables share a connector, and the connector connects to CNW12 connector on FTC4 (Slave).

When the THW1 and THW2 cables are too long, bundle the excess cables outside the FTC4 (Slave) unit.

Do not bind the wires in the FTC4 (Slave) unit.

<Thermistor position>

Place THW1 on **water** piping (water **outlet** side) after booster heater, and THW2 on the water inlet side.

It is recommended to protect the thermistor with heat insulating materials so as not to be affected by ambient temperature.

Note: Be sure to attach THW1 where it correctly detects Flow temp. (water outlet side). For more details, see Page 6.

⚠ Caution:

Do not route the thermistor cables together with power cables.

The sensor part of the thermistor should be installed where user can not access.

(It should be separated, by supplementary insulation, from areas the user can access.)

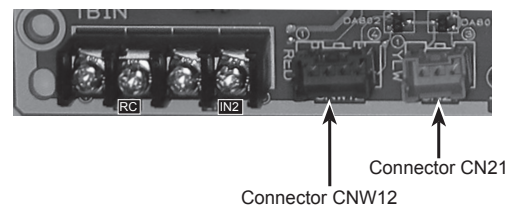

<Fig. 9.5.1>

9. Multiple outdoor units control

9.6 Dip switch functions

<Outdoor unit>

- Set refrigerant address on each outdoor unit from 1 to 6.

Note: Do NOT use refrigerant address 0 as 0 is used for FTC4 (Master). The address range is from 1 to 6.

Split model (SW1-3 to SW1-6)

Dip switch	Refrigerant address number					
	Add. 1	Add. 2	Add. 3	Add. 4	Add. 5	Add. 6
SW1-1	—	—	—	—	—	—
SW1-2	—	—	—	—	—	—
SW1-3	ON	OFF	ON	OFF	ON	OFF
SW1-4	OFF	ON	ON	OFF	OFF	ON
SW1-5	OFF	OFF	OFF	ON	ON	ON
SW1-6	OFF	OFF	OFF	OFF	OFF	OFF

<FTC4: Master>

- Set Dip SW4-1 and SW4-2 to ON.
- For more details refer to "5. Dip Switch setting."

<FTC4: Slave>

- Set Dip SW4-1 to ON "Active :multiple outdoor unit control".
- Set Dip SW1-7 (Outdoor unit type) on each slave unit according to each connected outdoor unit type.
- Set only Dip-SW1-3 to ON on the slave unit that runs DHW operation.

Packaged model (SW7-3 to SW7-6)

Dip switch	Refrigerant address number					
	Add. 1	Add. 2	Add. 3	Add. 4	Add. 5	Add. 6
SW7-1	—	—	—	—	—	—
SW7-2	—	—	—	—	—	—
SW7-3	ON	OFF	ON	OFF	ON	OFF
SW7-4	OFF	ON	ON	OFF	OFF	ON
SW7-5	OFF	OFF	OFF	ON	ON	ON
SW7-6	OFF	OFF	OFF	OFF	OFF	OFF

Dip switch		Function	OFF	ON	Master	Slave (PAC-SIF051B-E)	Slave *1 (Hydrobox)
SW1	SW1-1	Bolier	WITHOUT Bolier	WITH Bolier	✓	—	—
	SW1-2	Heat pump maximum outlet water temperature	55°C	60°C	✓	✓	✓
	SW1-3	DHW tank	WITHOUT DHW tank	WITH DHW tank	✓	✓	✓
	SW1-4	Immersion heater	WITHOUT Immersion heater	WITH Immersion heater	✓	—	—
	SW1-5	Booster heater	WITHOUT Booster heater	WITH Booster heater	✓	—	—
	SW1-6	Booster heater function	For heating only	For heating and DHW	—	—	—
	SW1-7	Outdoor unit type	Split type	Packaged type	—	✓	✓
	SW1-8	Wireless remote controller	WITHOUT Wireless remote controller	WITH Wireless remote controller	✓	—	—
SW2	SW2-1	Room thermostat1 input (IN1) logic change	Zone1 operation stop at short	Zone1 operation stop at open	✓	—	—
	SW2-2	Flow switch1 input (IN2) logic change	Failure detection at short	Failure detection at open	✓	✓	✓
	SW2-3	Booster heater capacity restriction	Inactive	Active	✓	—	—
	SW2-4	Cooling mode function	Inactive	Active	✓	—	—
	SW2-5	"Automatic switch to backup heater only operation (When outdoor unit stops by error)"	Inactive	Active	✓	—	—
	SW2-6	Mixing tank	WITHOUT Mixing tank	WITH Mixing tank	✓*2	—	—
	SW2-7	2-zone temperature control	Inactive	Active	✓	—	—
	SW2-8	—	—	—	—	—	—
SW3	SW3-1	Room thermostat2 input (IN6) logic change	Zone2 operation stop at short	Zone2 operation stop at open	✓	/	—
	SW3-2	Flow switch2 input (IN3) logic change	Failure detection at short	Abnormality detection at open	✓		—
	SW3-3	Flow switch3 input (IN7) logic change	Failure detection at short	Abnormality detection at open	✓		—
	SW3-4	Cooling operation in zone2	NOT in use	In use	✓		—
	SW3-5	Heating mode function	Inactive	Active	✓		—
	SW3-6	—	—	—	—		—
	SW3-7	—	—	—	—		—
	SW3-8	—	—	—	—		—
SW4	SW4-1	Multiple unit control	Inactive	Active	ON	ON	ON
	SW4-2	Position of multiple outdoor units control	Slave	Master	ON	OFF	OFF
	SW4-3	—	—	—	—	—	—
	SW4-4	—	—	—	—	—	—
	SW4-5	Emergency mode (Heater only operation)	Normal	"Emergency mode (Heater only operation) (To be activated only when powered ON)"	✓	—	—
	SW4-6	Emergency mode (Bolier operation)	Normal	"Emergency mode (Bolier operation) (To be activated only when powered ON)"	✓	—	—

✓ : Setting is required

— : NO setting (function is not available)

*1 When FTC4 (Master) in Hydrobox is set as Slave.

*2 Set Dip SW2-6 to ON in "System 3 (2 zone)" and in "System 4 (with Boiler)" mentioned in "9.2 Pipe work."

9. Multiple outdoor units control

9.7 Connecting inputs/outputs

When the wires are wired to adjacent terminals use ring terminals and insulate the wires.

<Electrical connection for master controller>

- Refer to "4.5 Connecting inputs/outputs"

<Electrical connection for slave controller>

■ PAC-IF051B-E

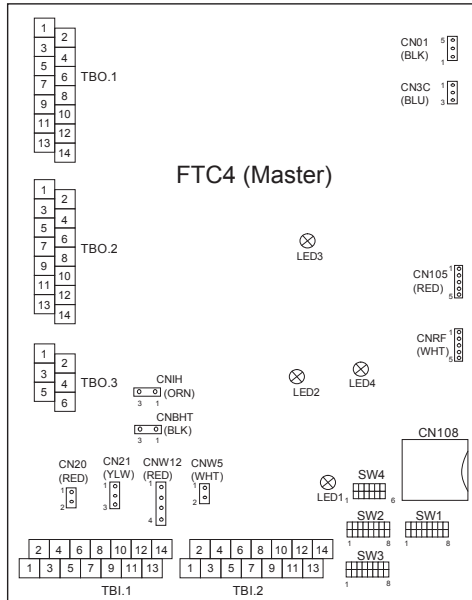

<Fig. 9.7.1>

Signal inputs

Name	Terminal block	Connector	Item	OFF (Open)	OFF (Short)
RC	TBI.2 13-14	—	Communication cable between indoor units	—	—
IN2	TBI.1 3-4	—	Flow switch 1 input	Refer to SW2-2 in <9.6 Dip Switch Functions>.	

Wiring specification and field supply parts

Item	Name	Model and specifications
Signal input function	Signal input wire	Use sheathed vinyl coated cord or cable. Max. 10 m Wire type: CV, CVS or equivalent Wire size: Stranded wire 0.5 mm ² to 1.25 mm ² Solid wire: ϕ 0.65 mm to ϕ 1.2 mm
	Switch	Non-voltage "a" contact signals Remote switch: minimum applicable load 12V DC, 1mA

Thermistor inputs

Name	Terminal block	Connector	Item	Optional part model
TH2	—	CN21	Thermistor (Ref. liquid temp.)	—
THW1	—	CNW12 1-2	Thermistor (Flow water temp.)	—
THW2	—	CNW12 3-4	Thermistor (Return water temp.)	—

Note:

Do not splice the wiring to extend or shorten it, or this could affect correct monitoring of each temperature.

If the wiring is too long, bundle it with a strap to adjust the length.

Outputs

Name	Terminal block	Connector	Item	OFF	ON	Signal/Max current
OUT1	TBO.1 3-4	—	Water circulation pump 1 output	OFF	ON	230V AC 1.0 A Max
OUT4	TBO.1 9-11	—	3-way valve (2-way valve 1) output	Heating	DHW	230V AC 0.1 A Max
OUT13	TBO.2 7-8	—	2-way valve 2 output	DHW	Heating	230V AC 0.1 A Max

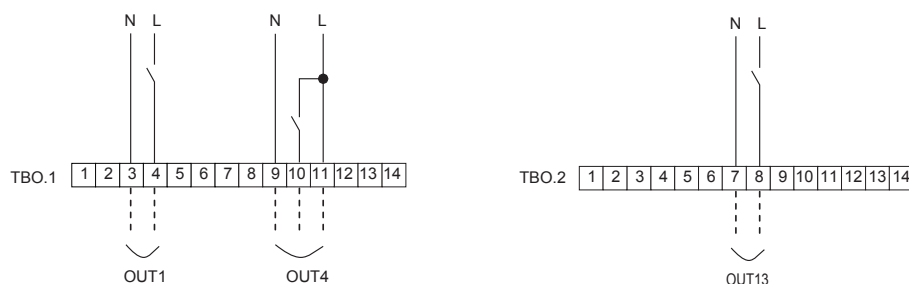

<Fig. 9.7.2>

9. Multiple outdoor units control

Wiring specification and field supply parts

Item	Name	Model and specifications
External output function	Outputs wire	Use sheathed vinyl coated cord or cable. Max. 30 m Wire type: CV, CVS or equivalent Wire size: Stranded wire 0.5 mm ² to 1.25 mm ² Solid wire: ø0.65 mm to ø1.2 mm

Note: Do not connect multiple water circulation pumps directly to each output (OUT1). In such a case, connect them via (a) relay(s).

■ PAC-SIF051B-E

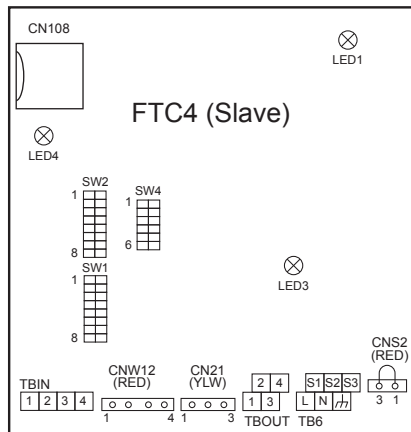

<Fig. 9.7.3>

Signal inputs

Name	Terminal block	Connector	Item	OFF (Open)	OFF (Short)
RC	TBIN 1-2	—	Communication cable between indoor units	—	—
IN2	TBIN 3-4	CN2F	Flow switch input	Refer to SW2-2 in <9.6 Dip Switch Functions>.	

Wiring specification and field supply parts

Item	Name	Model and specifications
Signal input function	Signal input wire	Use sheathed vinyl coated cord or cable. Max. 10 m Wire type: CV, CVS or equivalent Wire size: Stranded wire 0.5 mm ² to 1.25 mm ² Solid wire: ø0.65 mm to ø1.2 mm
	Switch	Non-voltage "a" contact signals Remote switch: minimum applicable load 12V DC, 1mA

Thermistor inputs

Name	Terminal block	Connector	Item	Optional part model
TH2	—	CN21	Thermistor (Ref. liquid temp.)	—
THW1	—	CNW12 1-2	Thermistor (Flow water temp.)	—
THW2	—	CNW12 3-4	Thermistor (Return water temp.)	—

Note:

Do not splice the wiring to extend or shorten it, or this could affect correct monitoring of each temperature.

If the wiring is too long, bundle it with a strap to adjust the length.

Output

Name	Terminal block	Connector	Item	OFF	ON	Signal/Max current
OUT1	TBOUT 1-2	—	Water circulation pump 1 output	OFF	ON	230V AC 1.0 A Max

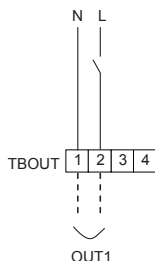

<Fig. 9.7.4>

Wiring specification and field supply parts

Item	Name	Model and specifications
External output function	Outputs wire	Use sheathed vinyl coated cord or cable. Max. 30 m Wire type: CV, CVS or equivalent Wire size: Stranded wire 0.5 mm ² to 1.25 mm ² Solid wire: ø0.65 mm to ø1.2 mm

Note: Do not connect multiple water circulation pumps directly to each output (OUT1). In such a case, connect them via (a) relay(s).

9. Multiple outdoor units control

Hydrobox

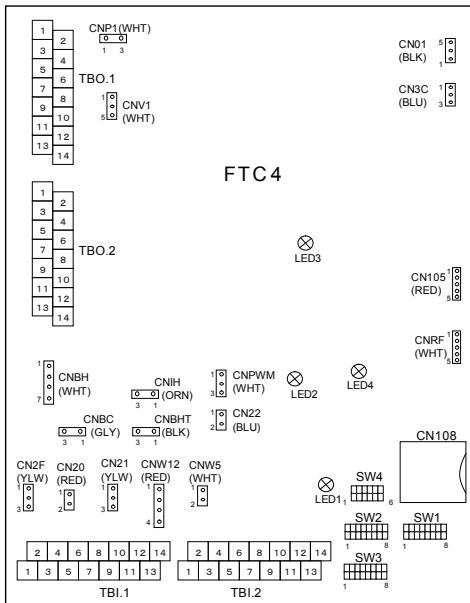

<Fig. 9.7.5>

Signal inputs

Name	Terminal block	Connector	Item	OFF (Open)	OFF (Short)
RC	TBI.2 13-14	CN22	Communication cable between indoor units	—	—
IN2	TBI.1 3-4	CN2F	Flow switch input	Refer to SW2-2 in <9.6 Dip Switch Functions>.	

Wiring specification and field supply parts

Item	Name	Model and specifications
Signal input function	Signal input wire	Use sheathed vinyl coated cord or cable. Max. 10 m Wire type: CV, CVS or equivalent Wire size: Stranded wire 0.5 mm ² to 1.25 mm ² Solid wire: ø0.65 mm to ø1.2 mm
	Switch	Non-voltage "a" contact signals Remote switch: minimum applicable load 12V DC, 1mA

Thermistor inputs

Name	Terminal block	Connector	Item	Optional part model
TH2	—	CN21	Thermistor (Ref. liquid temp.)	—
THW1	—	CNW12 1-2	Thermistor (Flow water temp.)	—
THW2	—	CNW12 3-4	Thermistor (Return water temp.)	—

Note:

Do not splice the wiring to extend or shorten it, or this could affect correct monitoring of each temperature.
If the wiring is too long, bundle it with a strap to adjust the length.

Outputs

Name	Terminal block	Connector	Item	OFF	ON	Signal/Max current
OUT1	TBO.1 3-4	CNP1	Water circulation pump 1 output	OFF	ON	230V AC 1.0 A Max
OUT4	TBO.1 9-11	CNV1	3-way valve (2-way valve 1) output	Heating	DHW	230V AC 0.1 A Max
OUT13	TBO.2 7-8	—	2-way valve 2 output	DHW	Heating	230V AC 0.1 A Max

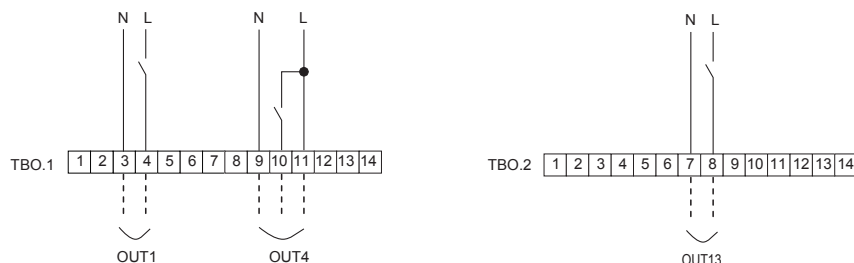

<Fig. 9.7.2>

Wiring specification and field supply parts

Item	Name	Model and specifications
External output function	Outputs wire	Use sheathed vinyl coated cord or cable. Max. 30 m Wire type: CV, CVS or equivalent Wire size: Stranded wire 0.5 mm ² to 1.25 mm ² Solid wire: ø0.65 mm to ø1.2 mm

Note: Do not connect multiple water circulation pumps directly to each output (OUT1). In such a case, connect them via (a) relay(s).

9. Multiple outdoor units control

■ Basic Troubleshooting for multiple outdoor units control

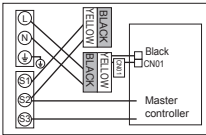
No.	Fault symptom	Possible cause	Explanation - Solution
1	Main controller display is blank.	<ol style="list-style-type: none"> There is no power supply to main controller. Power is supplied to the main controller, however, the display on the main controller does not appear. 	<ol style="list-style-type: none"> Check LED2 on the master controller. (See <Figure 5.2.1>.) <ol style="list-style-type: none"> When LED2 is lit. Check for damage or contact failure of the main controller wiring. When LED2 is blinking. Refer to No. 4 below. When LED2 is not lit. Refer to No. 3 below. Check the following: <ul style="list-style-type: none"> Disconnection between the main controller cable and the master controller. Failure of the main controller if "Please Wait" is not displayed. Refer to No. 2 below if "Please Wait" is displayed.
2	"Please Wait" remains displayed on the main controller.	<ol style="list-style-type: none"> "Please Wait" is displayed for up to 6 minutes. Communication failure between the main controller and master/slave controller. Communication failure between slave controller and outdoor unit. 	<ol style="list-style-type: none"> Normal operation. 3. Main controller start up checks/procedure. <ol style="list-style-type: none"> If "0%" or "50-99%" is displayed below "Please Wait" there is a communication error between the main controller and the master/slave controller. <ul style="list-style-type: none"> Check wiring connections on the main controller. Replace the main controller or master/slave controller. If "1-49%" is displayed there is a communication error between the outdoor unit's control board and slave controller. <ul style="list-style-type: none"> Check the wiring connections on the outdoor unit control board and the slave controller. (Ensure S1 and S2 are not cross-wired and S3 is securely wired with no damage. (See section 4.5.) Replace the outdoor unit's control board and/or the slave controller.
3	LED2 on master controller is off. (See <Figure 5.2.1>.)	<p>When LED1 on master controller is also off. (See <Figure 5.2.1>.)</p> <ol style="list-style-type: none"> Master controller is not supplied with 220 to 240V AC. There are problems in the method of connecting the connectors. Master controller failure. 	<ol style="list-style-type: none"> Check the voltage across the L and N terminals on the indoor power supply terminal block. (See section 4.5.) <ul style="list-style-type: none"> When the voltage is not 220 to 240V AC, check for faulty wiring to power supply. When the voltage is 220 to 240V AC, go to 2. below. Check for faulty wiring between the connectors. <ul style="list-style-type: none"> When the connectors are wired incorrectly re-wire them correctly referring to below. (See section 4.5 and a wiring diagram on the control and electrical box cover.)  <ol style="list-style-type: none"> If no problem found with the wiring, go to 3. below. Check the master controller. <ul style="list-style-type: none"> Check the fuse on the master controller. Check for faulty wiring. Check Dip SW4-2 is ON. If no problem found with the wiring, the master controller is faulty.
4	LED2 on FTC4 is blinking. (See Figure <5.2.1>)	<p>When LED1 is also blinking on master controller.</p> <p>When LED1 on master controller is lit.</p> <ol style="list-style-type: none"> Faulty wiring in main controller Multiple indoor units have been wired to a single outdoor unit. Short-circuited wiring in main controller Main controller failure Dip SW setting failure 	<p>Check for faulty wiring between master controllers.</p> <ol style="list-style-type: none"> Check for faulty wiring in main controller. The number of indoor units that can be wired to a single outdoor unit is one. Additional indoor units must be wired individually to a single outdoor unit. 3. Remove main controller wires and check LED2 on master controller. (See Figure 5.2.1.) <ul style="list-style-type: none"> If LED2 is blinking check for short circuits in the main controller wiring . If LED2 is lit, wire the main controller again and: <ul style="list-style-type: none"> - if LED2 is blinking, the main controller is faulty; - if LED2 is lit, faulty wiring of the main controller has been corrected. Check Dip SW 4-2 on the slave controller is OFF.

For other details, refer to "8. Troubleshooting".

10. Supplementary information

10.1 Refrigerant collecting (pumpdown) for split model systems only

Refer to "Refrigerant collection" in the outdoor unit installation manual or service manual.

10.2 Back-up operation of boiler

Heating operation is backed up by boiler.

For more details, refer to the installation manual of PAC-TH011HT-E.

<Installation & System set up>

1. Set Dip-SW 1-1 to ON "With boiler" and SW2-6 to ON "With Mixing tank".
2. Install the thermistors THWB1 (Flow temp.) and THWB2 (return temp.) *1 on the boiler circuit.
3. Connect the output wire (OUT10: Boiler operation) to the signal input (room thermostat input) on the boiler. *2
4. Install one of the following room temp. thermostats. *3
 - Wireless remote controller (option)
 - Room temp. thermostat (field supply)
 - Main controller (remote position)

*1 The boiler temp. thermistor is an optional part.

*2 OUT10 has no voltage across it.

*3 Boiler heating is controlled on/off by the room temp. thermostat.

<Remote controller settings>

1. Go to Service menu > Heat source setting and choose "Boiler" or "Hybrid". *3
2. Go to Service menu > Operation settings > Boiler settings to make detailed settings for "Hybrid" above .

*3 The "Hybrid" automatically switches heat sources between Heat pump (and Electric heater) and boiler.

Local application factors

- * This FTC4 is designed to connect Mr.Slim/Ecodan inverter outdoor unit of MITSUBISHI ELECTRIC to local systems. Please check the following when designing the local system.
- * MITSUBISHI ELECTRIC does not take any responsibility for the local system design.

Heat exchanger

(1) Withstanding pressure

Designed pressure of outdoor unit is 4.15 MPa. Following must be satisfied for burst pressure of connecting application.

Burst pressure: More than 12.45 MPa (3 times more than designed pressure)

(2) Performance

Secure the heat exchanger capacity which meets the following conditions. If the conditions are not met, it may result in malfunction caused by the protection operation or the outdoor unit may be turned off due to the operation of protection system.

- In case of hot water supply, condense temperature is less than 58 °C in max. frequency operation with the outside temperature 7 °C D.B./6 °C W.B.

(3) Heat exchanger internal capacity

Heat exchanger internal capacity must be within the capacity range shown below. If the heat exchanger below the minimum capacity is connected, it may result in the back flow of liquid or the failure of the compressor.

If the heat exchanger above the maximum capacity is connected, it may result in the deficiency in performance due to lack of refrigerant or overheating of the compressor.

Minimum capacity: $10 \times \text{Model capacity [cm}^3\text{]}$ / Maximum capacity: $30 \times \text{Model capacity [cm}^3\text{]}$

e.g. When connecting to PUHZ-HRP100 VHA

Minimum capacity : $10 \times 100 = 1000 \text{ cm}^3$

Maximum capacity : $30 \times 100 = 3000 \text{ cm}^3$

Model capacity	35	50	60	71	100	125	140	200	250
Maximum capacity [cm ³]	1050	1500	1800	2130	3000	3750	4200	6000	7500
Minimum capacity [cm ³]	350	500	600	710	1000	1250	1400	2000	2500

(4) Contamination maintenance

1. Wash the inside of heat exchanger to keep it clean. Be sure to RINSE not to leave flux. Do not use chlorine detergent when washing.

2. Be sure that the amount of contamination per unit cubic content of heat transfer pipe is less than the following amount.

Example) In case of $\phi 9.52 \text{ mm}$

Residual water: 0.6 mg/m, Residual oil: 0.5 mg/m, Solid foreign object: 1.8 mg/m

Thermistor position

Refer to 4.4.

Notes

- Install the hydraulic filter at the water inlet pipework.
- Inlet water temperature of heat exchanger should be within the range 5 °C - 55 °C.
- Water quality should be to European Directive 98/83 EC standards
 - pH value of 6.5 - 8
 - Calcium $\leq 100 \text{ mg/L}$
 - Chlorine $\leq 100 \text{ mg/L}$
 - Iron/Manganese $\leq 0.5 \text{ mg/L}$
- Refrigerant pipe diameter from outdoor unit to refrigerant-water HEX (Only for SPLIT type)
 - Use the pipe with same diameter size as the refrigerant pipe connection diameter of outdoor unit. (Refer to outdoor unit installation manual.)
- Ensure that there is sufficient anti-freeze chemical in the water circuit. It is recommended to use 7 : 4 anti-freeze to water ratio.
- The water velocity in pipes should be kept within certain limits of material to avoid erosion, corrosion and excessive noise generation.
 - Be aware, and take care of , that local velocities in small pipes, bends and similar obstructions can exceed the values above.
 - e.g.) Copper: 1.5 m/s

⚠ Warning:

- **Always use water that meets the above quality requirements. Using water that does not meet these standards may result in damage to the system pipework and heating components.**
- **Never use anything other than water as a medium. It may cause a fire or an explosion.**
- **Do not use heated water that is produced by the air to water heat pump directly for drinking or cooking. There is a risk to damage your health. There is also a risk that installing the water heat exchanger may corrode if the necessary water quality for air to water heat pump system cannot be maintained. If you wish to use the heated water from the heated pump for these purposes, take measure such as to the second heat exchanger within the water piping system.**

EC DECLARATION OF CONFORMITY
EG-KONFORMITÄTSERKLÄRUNG
DÉCLARATION DE CONFORMITÉ CE

EG-CONFORMITEITSVERKLARING
DECLARACIÓN DE CONFORMIDAD CE
DICHIARAZIONE DI CONFORMITÀ CE

DECLARAÇÃO DE CONFORMIDADE CE
EU-OVERENSTEMMELSESERKLÆRING
EG-DEKLARATION OM ÖVERENSSTÄMMELSE

CE-ERKLÆRING OM SAMSVAR
CE-VAAIMUSTENMUKAISUUSVAKUUTUS

mitsubishi electric air conditioning systems europe ltd.
NETTLEHILL ROAD, HOUSTOUN INDUSTRIAL ESTATE, LIVINGSTON, EH54 5EQ, SCOTLAND, UNITED KINGDOM

hereby declares under its sole responsibility that the heating system components described below for use in residential, commercial and light-industrial environments:
erklärt hiermit auf seine alleinige Verantwortung, dass die unten beschriebenen Zubehörteile für das Heizungs- / Kühlungs-System zur Benutzung im häuslichen, kommerziellen und leicht-industriellen Umfeld:
déclare par la présente et sous son entière responsabilité que les composants du système de chauffage/refroidissement décrits ci-dessous pour l'utilisation dans des environnements résidentiels, commerciaux et d'industrie légère :
verklaart hierbij als enige verantwoordelijke dat de componenten van het verwarmings-/koelsysteem die hieronder worden beschreven, bedoeld zijn voor gebruik in woonomgevingen en in commerciële en licht industriële omgevingen:
declara por la presente bajo su responsabilidad exclusiva que los componentes del sistema de calefacción/refrigeración descritos a continuación para su uso en zonas residenciales, comerciales y para la industria ligera:
con la presente dichiara, sotto la sua esclusiva responsabilità, che i componenti dell'impianto di riscaldamento/raffreddamento descritto di seguito, destinato all'uso in ambienti residenziali, commerciali e industriali:
através da presente declara sob sua única responsabilidade que os componentes do sistema de aquecimento/arrefecimento abaixo descritos para uso residencial, comercial e de indústria ligeira:
erklærer hermed under eneansvar, at de herunder beskrevne komponenter til opvarmning/køling til brug i privat boligbyggeri, erhvervsområder og inden for let industri:
intyggar härmed att uppvärmnings/nedkylningssystemkomponenterna som beskrivs nedan är för användning i bostäder, kommersiella miljöer och lätt industri:
erklærer hermed som sitt ansvar, ene og alene, at komponentene i varme- og kjølesystemet som beskrives nedenfor og som er beregnet for bruk i bolig-, forretnings- og lettindustri miljøer:
vakuuttaa täten asiasta yksin vastuussa, että alla kuvatut lämmitys/jäähdytysjärjestelmän osat, jotka on tarkoitettu käytettäväksi asuin-, toimisto- ja kevyen teollisuuden ympäristöissä:

mitsubishi electric, PAC-IF051B-E, PAC-IF052B-E, PAC-SIF051B-E

Note: Its serial number is on the nameplate of the product.
Hinweis: Die Seriennummer befindet sich auf dem Kennschild des Produkts.
Remarque : Le numéro de série de l'appareil se trouve sur la plaque du produit.
Opmerking: het serienummer staat op het naamplaatje van het product.
Nota: El número de serie se encuentra en la placa que contiene el nombre del producto.
Nota: il numero di serie si trova sulla targhetta del prodotto.

Nota: o número de série encontra-se na placa que contém o nome do produto.
Bemærk: Seriennummeret står på produktets fabrikskilt.
Obs: Serienumret finns på produktens namnplåt.
Merk: Seriennummeret befinner seg på navneplaten til produktet.
Huomautus: Sen sarjanumero on tuotteen nimikilvessä.

Directives
Richtlinien
Directives
Richtlijnen
Directivas
Direttive

Directivas
Direktiver
Direktiv
Direktiver
Direktiviit

2006/95/EC: Low Voltage
2006/42/EC: Machinery
2004/108/EC: Electromagnetic Compatibility

Our authorized representative in EU, who is authorized to compile the technical file, is as follows.
Unser autorisierter Vertreter in der EU, der ermächtigt ist die technischen Daten zu kompilieren, ist wie folgt.
Notre représentant agréé dans L'UE, qui est autorisé à compiler le fichier technique, est le suivant.
Onze geautoriseerde vertegenwoordiger in de EU, die gemachtigd is het technische bestand te compileren, is als volgt.
Nuestro representante autorizado en la UE, que está autorizado para compilar el archivo técnico, es el siguiente.
Il nostro rivenditore autorizzato nell'UE, responsabile della stesura della scheda tecnica, è il seguente.

O nosso representante autorizado na UE, que está autorizado para compilar o ficheiro técnico, é o seguinte:
Vores autoriserede repræsentant i EU, som er autoriseret til udarbejdelse af den tekniske fil, er følgende.
Vår EG-representant som är auktoriserad att sammanställa den tekniska filen är följande.
Vår autoriserte EU-representant, som har autorisasjon til å utarbeide denne tekniske filen, er som følger.
Valtuutettu edustajamme EU:ssa, jolla on lupa laatia tekninen tiedosto, on seuraava.

mitsubishi electric europe, b.v.
HARMAN HOUSE, 1 GEORGE STREET, UXBRIDGE, MIDDLESEX UB8 1QQ, U.K.
Yoji SAITO
Product Marketing Director

Issued
LIVINGSTON

1 July, 2012

Atsuhiko YABU
President

Installers: Please be sure to put your contact address/telephone number on
this manual before handing it to the customer.



mitsubishi electric corporation

HEAD OFFICE: TOKYO BLDG., 2-7-3, MARUNOUCHI, CHIYODA-KU, TOKYO 100-8310, JAPAN
Authorized representative in EU: MITSUBISHI ELECTRIC EUROPE B.V.

HARMAN HOUSE, 1 GEORGE STREET, UXBRIDGE, MIDDLESEX UB8 1QQ, U.K.

This product is made by Mitsubishi Electric Air Conditioning Systems Europe Ltd.: NETTLEHILL Rd, HOUSTOUN IND ESTATE,
LIVINGSTON, EH54 5EQ, UK